HIDROS

WATER COOLED WATER CHILLERS AND HEAT PUMPS

WSK

SERIES



CE

TECHNICAL MANUAL

HIDROS

Via dell'Industria, 5
35010 Brugine PD Italy

Tel. 0039 049 9731022
Fax 0039 049 5806928

CE 1370

Organismo notificato / Organisme notifié
Notified body/Meldestelle/Anmält organ:

Bureau Veritas Italia

**DICHIARAZIONE DI CONFORMITA'
DECLARATION DE CONFORMITE
DECLARATION OF CONFORMITY
KONFORMITÄTSERKLÄRUNG
FÖRSÄKRAN OM ÖVERENSSTÄMMESE**

**BRUGINE
25/07/06**

Macchina Modello / Unité Modéle / UNIT Model
Gerät Typ / Enhet Modell:

Matricola / Matricule / Serial no.
Serie nummer / Serienr

Direttive CEE / Directives CEE / EEC directive / CEE Richtlinie / EEC-direktiv:

(1)

- **98/37 CE** Sicurezza delle macchine / Sécurité des machines / Safety of machinery / Sicherheit von Maschinen / Maskinsäkerhet.
 - **89/336 CE** Compatibilità elettromagnetica / Compatibilité électromagnétique / Electromagnetic compatibility / Elektromagnetische Verträglichkeit / Elektromagnetisk kompatibilitet.
 - **73/23 CE** Bassa tensione / Baisse tension / Low Voltage / Niedrige Spannung / Låg spännin
 - **97/23 CE** Dispositivi in pressione / Equipement sous pression / Under pressure devices / Drucksysteme entspricht / Tryckbärande anordnin
 - **2002/95 CE** Sostanze pericolose nelle apparecchiature elettr. / Substances dangereuses dans les équipements électr. / Hazardous substances in electr. equipment / Verwendung bestimmter gefährlicher Stoffe in der Elektronikgeräten
 - **2002/96 CE** Rifiuti di apparecchiature elettr. / déchets d'équipements électr. / Waste in electr. Equipment / Elektro- und Elektronik-Altgeräte / eller innehåller elektriska eller elektroniska produkter
- e loro successive integrazioni / et leurs intégrations suivantes / and their following amendments / und ihre folgende Verkündigungen /

- Normative - Normes - Standards - Rechtsvorschriften - Normer :

(2)

- **EN 60204-1 12/1997** Sicurezza del macchinario-Equipaggiamento elettrico-Parte 1: Regole generali / Sécurité des machines-Equipement électrique-Partie 1: Règles générales / Safety machinery-electrical equipment of machines -Part 1: General requirements / 'Sicherheit von Maschinen; elektrische Ausrüstung von Maschinen. Teil 1: allgemeine Anforderung / Maskinsäkerhet-Elutrustning för maskiner-Allmänna fordringar.
- **EN 61000-6-4 2001** Compatibilità elettromagnetica-Norma generica sull'emissione-Parte 4: Ambiente industriale / Compatibilité électromagnétique-Norme générique émission-Partie 4: Environnement industriel / Electromagnetic compatibility-Generic emission standard-Part 4: Industrial environment / Elektromagnetische Verträglichkeit-Allgemeine Bestimmung über die Emission-Teil 4: industrieller Raum / Elektromagnetisk kompatibilitet-Emission-Del 4: Generella fordringar på utrustning i industrimiljö.
- **EN 61000-6-2 2001** Compatibilità elettromagnetica-Norma generica sull'immunità-Parte 2: Ambiente industriale / Compatibilité électromagnétique-Norme générique immunité-Partie 2: Environnement industriel / Electromagnetic compatibility-Generic immunity standard-Part 2: Industrial environment □□□ Flüssigkeitssammler* / Reciver* Elektromagnetische Verträglichkeit-Allgemeine Bestimmung über die Immunität-Teil 2: industrieller Raum / Elektromagnetisk kompatibilitet -Immunitet-Del 2: Generella fordringar på utrustning i industrimiljö.
- **EN 292/2 09/1991** Sicurezza del macchinario - Concetti fondamentali, principi generali di progettazione. Specifiche e principi tecnici. / Critères fondamentaux, principes généraux de projet. Specifications et principes techniques. / Safety of machinery - Basic concepts, General principles for design Part 2: Technical principles specification / Grundbegriffe, allgemeine. Gestaltungsleitsätze, technische Leitsätze und Spezifikationen. Maskinsäkerhet-Grundläggande begrepp, allmänna konstruktionsprinciper-Del 2: Tekniska principer
- **EN 294 06/1992** Sicurezza del macchinario - Distanze di sicurezza per impedire il raggiungimento di zone pericolose con gli arti superiori. Distances de sécurité pour empêcher le contact des membres supérieurs avec des zones dangereuses. Safety standards (avoidance of personal injury). / Sicherheitsabstände gegen das Erreichen von Gefahrenstellen mit den oberen Gliedmaßen. / Maskinsäkerhet-Skyddsavstånd för att hindra att man når riskområden med händer och armar.
- **EN 349 04/1993** Sicurezza del macchinario - Spazi minimi per evitare lo schiacciamento di parti del corpo umano. / Espaces minimum pour éviter l'écrasement de parties du corps. / Safety of machinery - Minimum gaps avoid crushing of parts of the human body / Mindestabstände zur Vermeidung des Quetschens von Körpersteilen. / Maskinsäkerhet-Minimiumtrymme för att undvika att kroppsdelar krossas.
- **EN 378-2 01/2001** Dispositivi in pressione - Impianti di refrigerazione e pompe di calore: requisiti di sicurezza e ambientali - Parte 2: progettazione, costruzione, collaudo, installazione, marcatura e documentazione / Systèmes de réfrigération et pompes à chaleur - prescriptions en matière de sécurité et d'environnement 2e partie: conception, construction, test, installation, marquage et documentation / Refrigeration systems and heat pumps - Safety and environmental requirements - Part 2: design, construction, test, instation, marking and documentation / Kältemaschinen und Wärmepumpen - Sicherheits und Umweltbestimmungen - Teil 2: Design, Konstruktion, Abnahmeprüfungen, Installation, Kennzeichnung und technische Unterlagen / Kylsystem och värmepumpar - säkerhets och miljökrav - Del 2: design, konstruktion, provning, installation, märkning och dokumentation.

Moduli di valutazione di conformità alla direttiva 97/23 utilizzati per i componenti
Formulaire de évaluation de conformité avec la directive 97/23 CEE utilisés pour les composants
Procedures in compliance with 97/23 CEE directive to be used for the components
Konformitätprozedur nach der Richtlinie 97/23 CEE für die bauteile
Metod i överrenstämmande med 97/23 CEE standard som används för komponenter

Componente / Composant / Component / Bauteil / Komponent	Modulo/Proced./Proced./Prozed./Metod
Compressore / Compresseur / Compressor / Verdichter / Kompressor	D1
Evaporatore / Evaporateur / Evaporator / Verdampfer / Förångare	B+D / NA**
Condensatore / Condenseur / Condenser / Verflüssiger / Kondensator	B+D / NA**
Ricevitore* / Réservoir de liquide* / Liquid receiver* / Flüssigkeitssammler* / Receiver*	B+D / NA**
Separatore* / Separateur de liquide* / Liquid separator* / Abscheider* / Vätskeavskiljar	A1
Valvola sicurezza* / Vanne sécurité* / Safety valve* / Sicherheitsventil* / Säkerhetsventi	B+D
Pressostati di sicurezza / Pressostats / Safety pressure switch / Druckschalter / Pressosta	B+D
* se presente / si present / if presents / wenn vorhanden / om sådan finns monterd	
** se batteria alettata / si batterie à ailettes / if finned coil / bei beripptem register / vid lamellbatteri	

Certificato n° / Certificat n° / Certificate n° / Zertifikate N° / Certifikat n° : CE-PED-A1-HID001-05-BVI

Si dichiara, sotto la nostra responsabilità, che le forniture sopra indicate sono conformi in ogni parte alle direttive CEE di cui al punto (1). Le forniture sono state prodotte, collaudate e verificate con riferimento alle normative di cui al punto (2).

Nous déclarons sous notre responsabilité que les fournitures susmentionnées se conforment totalement aux directives CEE comme déclaré dans le point (1). Les fournitures ont été fabriquées, testées et contrôlées faisant référence aux normes susmentionnées au point (2).

We declare under our responsibility that the a.m. supplies are fully in conformity with the EEC regulations stated in the point (1). The equipment(s) have been manufactured, tested and checked following the standards stated in the point (2).

Wir bestätigen auf unsere Verantwortung, daß die oben angeführten Lieferungen den im Punkt (1) berichteten CEE Rechtsvorschriften voll entsprechen. Die Geräte wurden in Bezug auf die im Punkt (2) berichteten Vorschriften erzeugt und geprüft.

Vi försäkrar härmed att ovan nämnda produkter överensstämmer helt och hållet med de EEC-direktiv som anges i (1). Produkterna är tillverkade, testade och kontrollerade enligt de normer som anges i (2).

- Il Legale Rappresentante - Le P.D.G. - The Managing Director - Unser offizieller Vertreter - Vd :

Vittorio Pozza



INDEX

Declaration of conformity	page 2
Aim and contents of this manual	page 4
How to keep this manual	page 4
Graphic symbols	page 4
Safety laws	page 5
General safety guidelines	page 5
Workers' health and safety	page 6
Protective equipment	page 6
Safety signs	page 6
Technical Characteristics	page 7
Technical data	page 9
WSK cooling capacity and compressors input power	page 13
WSK/HP heating capacity and compressors input power	page 16
WSK/EV cooling capacity and compressors input power	page 19
Evaporator pressure drops	page 21
Condenser pressure drops	page 22
Water pumps available static pressure	page 23
Partial heat recovery capacity	page 24
Operation limits	page 25
Correction tables	page 26
Sound data	page 26
Safety device setting	page 27
Electrical data	page 27
Inspection	page 27
Lifting and handling	page 28
Location and minimum technical clearances	page 28
Hydraulic connections	page 29
Electrical connections	page 31
Start up	page 31
Microprocessor user interface	page 32
Remote keyboard	page 34
Controls during operation	page 37
Maintenance and periodic checks	page 37
Refrigerant circuit repair	page 38
Environment protection	page 38
Unit out of service	page 38
Fault finding	page 38
Dimensions	page 40

The WSK manual, contains any information that is needed for a correct use of the equipment while safeguarding operator safety, according to what indicated from "Council Directive" 98/37/CE and following changes.

AIM AND CONTENTS OF THIS MANUAL

This manual provides basic information on the installation, operation and maintenance off the WSK unit. It is addressed to machine operators and it enables them to use the equipment efficiently, even if they do not have any previous specific knowledge of it. This manual describes the characteristics of the equipment at the time it is being put on the market; therefore it may not capture later technological improvements introduced by HIDROS SRL as part of its constant endeavour to enhance the performance, ergonomics, safety and functionality of its products.

HOW TO KEEP THIS MANUAL

The manual must be always with the unit it refers to. It must be stored in a safe place, away from the dust and moisture. It must be accessible to all users who shall consult it any time they are in doubt on how to operate the equipment.

HIDROS SRL reserves the right to modify its products and related manuals without necessarily updating previous versions of the reference material. The customer shall store any updated copy of the manual or parts of it delivered by the manufacturer as an attachment to this manual.

HIDROS SRL is available to give any detailed information about this manual and to give information regarding the use and the maintenance of its own units.

GRAPHIC SYMBOLS



Indicates operations that can be dangerous for people and/or disrupts the correct operation of the equipment..



Indicates prohibited operations.



Indicates important information that the operator must follow in order to guarantee the correct operation of the equipment in complete safety

SAFETY LAWS

HIDROS SRL's equipment and their component parts have been designed in compliance with the harmonised EC norms in force and other European and national norms as required by the Council Directive (98/37 and later amendments).

The equipment is also compliant with:

- Norms EN 292-1 e 292-2
- Norma EN 294
- Norms EN 378-1, 378-2, 378-3 e 378-4
- Norma EN 418
- Norma EN 953
- Norma EN 1050
- Norma EN 60204-1
- Norma EN 61000-6-2
- Norma EN 61000-6-4
- Community Directives 98/37/CE, 97/23/CE, 93/68/CEE, 89/336/CEE 73/23/CEE

GENERAL SAFETY GUIDELINES

Before beginning to operate on WSK units every user must be perfectly knowledgeable about the functions of the equipment and its controls and must have read and understood the information container in this manual.



It's strictly forbidden to remove and/or tamper with any safety device.



Any routine or not-routine maintenance operation shall be carried out when the equipment has been shut down, disconnected from electric and pneumatic power source and after its pneumatic system has been discharged.



Do not put your hands or insert screwdrivers, spanners or other tools into moving parts of the equipment.



The equipment supervisor and the maintenance man must receive training suitable for the performance of their tasks in safety



Operators must know how to use personal protective devices and must know the accident-prevention guidelines contained in national and international laws and norms.

WORKERS' HEALTH AND SAFETY

The European Community has adopted a number of directives on workplace health and safety, which include directives **89/391/CEE**, **89/686/CEE**, **89/655/CEE**, **86/188/CEE** and **77/576/CEE**. Every employer shall implement such provisions and ensure that workers respect them:



Do not tamper with or replace parts of the equipment without the specific consent of the manufacturer. The manufacturer shall have no responsibility whatsoever in case of unauthorised operations.



Using components, expendable materials or spare parts that do not correspond to those recommended by the manufacturer and/or listed in this manual may be dangerous for the operators and/or damage the equipment



The operator's workplace must be kept clean, tidy and free from objects that may hamper free movements. Appropriate lighting of the work place shall be provided so as to allow the operator to carry out the required operations safely. Poor or too strong lighting can cause risks.



Ensure that work places are always adequately ventilated and that aspirators are working, in good condition and in compliance with the requirements of the laws in force...

PERSONAL PROTECTIVE EQUIPMENT

When operating and maintaining the WSK unit, use the following personal protective equipment.



Protective clothing: Maintenance men and operators must wear protective clothing that complies with the basic safety requirements currently in force. In case of slippery floors users must wear safety shoes with non-slip soles..



Gloves: During maintenance or cleaning operation protection gloves must be used.



Mask and goggles: Respiratory protection (mask) and eye protection (goggles) should be used during cleaning and maintenance operations.

SAFETY SIGNS

The equipment features the following safety signs, which must be complied with:



General hazard



Electric shock hazard

TECHNICAL CHARACTERISTICS

Frame

All WSK units are made from hot-galvanised thick sheet metal, painted with polyurethane powder enamel at 180°C to ensure the best resistance against the atmospheric agents. The frame is self-supporting with removable panels. All screws and rivets for outdoor installations are in stainless steel. The colour of the units is RAL 7035

Refrigerant circuit

The refrigerant gas used in these units is R407C. The refrigerant circuit is made by using international primary brands components and according to ISO 97/23 concerning welding procedures. The refrigerant circuit includes:

- sight glass,
- filter drier,
- thermal expansion valve with external equalizer,
- reverse cycle valve (for heat pump version only),
- one way valve (for heat pump version only),
- liquid receiver (for heat pump version only),
- Schrader valves for maintenance and control,
- pressure safety device (according to PED regulation).

Compressors

The compressors are scroll type (rotative type for sizes 04,05,07 only), with crankcase heater and thermal overload protection by a klixon embedded in the motor winding. The crankcase heater, when present, is always powered when the compressor is in stand-by. The inspection is possible through the frontal panel of the unit that allows the maintenance of the compressors even if the unit is working

Evaporators and condensers

The evaporators and the condensers are made of AISI 316 stainless steel braze-welded plates type. The use of these kind of evaporators allows a massive reduction of the refrigerant charge of the unit compared to the traditional shell-in-tube evaporators and also a reduction of the overall dimensions of the unit. The evaporators are factory insulated with flexible close cell material and can be equipped with antifreeze heater (optional). Each evaporator is provided with a temperature sensor as antifreeze protection

Electric box

The electric box is made according to electromagnetic compatibility norms CEE 73/23 and 89/336. The accessibility to the board is possible after removing the front panel of the unit. The protection degree is IP55. In all WSK units are installed, standard, the compressors sequence relay who disables the operation of the compressor in case the power supply phase sequence is not the correct one (scroll compressors in fact, can be damaged if they rotate reverse wise). The following components are also standard installed: main switch, magnetic-thermal switches (as a protection of pumps), compressors fuses, control circuit automatic breakers, compressor contactors, fan contactors, pump contactors. The terminal board is supplied with voltage free contacts for remote ON-OFF, Summer / winter change over (heat pumps only) and general alarm

Microprocessors

All WSK units are supplied standard with microprocessor controls. The microprocessor controls the following functions: regulation of the water temperature, antifreeze protection, compressor timing, compressor automatic starting sequence, alarm reset, potential free contact for remote general alarm, alarms and operation leds. Upon request any microprocessor can be connected to a BMS system for the remote control and management. The technical department is available to study, together with the customer, different solutions using MODBUS; LONWORKS; BACNET or TREND protocols

Control and protection devices

All units are supplied with the following control and protection devices: Return water temperature sensor, installed on the return water line from the plant (12°C), antifreeze protection sensor installed on the outlet water temperature (7°C), high pressure switch with manual reset, low pressure switch with automatic reset, high pressure safety valve, compressor thermal overload protection, fans thermal overload protection, flow switch

OTHER VERSIONS

WSK/A1 with integrated hydraulic kit: The WSK chillers can be delivered as option, with a built in hydraulic kit that includes:

Water tank in different sizes (depending on the size of the unit), factory insulated with flexible close cell material and prepared for the installation of antifreeze kit (option). The water tank is installed on the water outlet side to minimize the inevitable fluctuations in the water temperature (7°C) due to the compressors starts and stops. The installation of the water tank on the water outlet side (7°C) keeps constant, for a period of time, the user water temperature when the compressors are Off, while this can not be obtained if the water tank is installed on the water inlet side (12°C).

Water pump, centrifugal type, suitable for chilled water operation. The pump is directly controlled by the microprocessor that controls its correct operation. In the hydraulic circuit are also present the expansion vessel, the safety valve and the eventual manual valves with fittings.

Moto evaporating version (EV)

The moto evaporating versions are supplied without condenser and refrigerant charge (only a nitrogen charge). This version has to be connected to a remote condenser. The microprocessor control is present in all units.

Heat pump version (HP)

The heat pump versions are provided with a 4 way reverse cycle valve and are suitable to produce hot water up to a temperature of 45-48°C. They are always supplied with liquid receiver and a second thermostatic valve to optimize the efficiency of the refrigerant cycle in heating and in cooling. The microprocessor is set for automatic defrost (in case of operation in severe ambient conditions) and for summer/winter change over.

ACCESSORIES**Remote control panel**

It allows the remote control of all parameters of the unit

Rubber vibration dampers

To be installed beneath the unit base and the ground to avoid the transmission of vibrations (and the noise) to the building.

Pressostatic valve kits

This device is composed by a pressostatic valve who modulates the water flow to the condenser in order to keep constant the condensing temperature. This device is mainly used to reduce the water consumption of the unit in those applications where the external circuit is open (underground water, etc.). In case the external circuit is using recirculation water the use of the pressostatic valve can be avoided. In heat pump versions (HP) the kit is also composed by a solenoid valve who by pass completely the pressostatic valve in heating mode. It is important to know that in heating mode the water consumption will not be controlled by the valve kit.

Interface card

It is composed by an electronic card to be installed and connected to the unit microprocessor, it allows the control of the unit via serial line (RS485) and personal computer.

**WATER CHILLERS AND HEAT PUMPS
WSK
TECHNICAL DATA**

Mod.		04	05	07	09	13	15	
Refrigerant		R407C	R407C	R407C	R407C	R407C	R407C	
Cooling capacity	Kw	4,1	5,0	7,7	9,1	13,7	16,4	
Compressor input power	Kw	1,2	1,5	2,3	2,7	4,0	4,7	
Evaporator water flow	l/h	700	860	1320	1560	2360	2820	
Evaporator pressure drops	Kpa	17,0	12,0	24,0	26,0	28,0	32,0	
Condenser water consumption*	l/h	230	280	430	510	760	910	
Condenser pressure drops*	Kpa	18	25	27	28	33	30	
Condenser water flow**	l/h	910	1120	1720	2030	3050	3630	
Condenser pressure drops**	Kpa	25	32	37	40	35	39	
Heating capacity	Kw	5,5	6,7	10,3	12,0	18,0	21,7	
Compressor input power	Kw	1,3	1,7	2,5	2,9	4,3	5,0	
Condenser water flow	l/h	945	1150	1770	2060	3100	3730	
Condenser pressure drops	Kpa	26,5	29	38	40	42	48	
Evaporator water consumption	l/h	720	860	1340	1560	2350	2870	
Evaporator pressure drops	Kpa	17,5	12,0	24,0	26,0	28,0	32,0	
Nominal input current (A version)	A	11	13,5	18,6	21,7	12,0	13,0	
Peak current	A	38	50	79	103	15,0	15,0	
Maximum input current	A	13	14,4	20,3	26,1	69,0	77,0	
Power supply	V/Ph/Hz	230/1/50				400/3+N/50		
Compressor	tipo	Scroll						
	n°	1	1	1	1	1	1	
Sound power level ⁽¹⁾	dB(A)	50	51	52	52	54	54	
Sound pressure level ⁽²⁾	dB(A)	42	43	44	44	46	46	
Water tank capacity (Version A1)	lt.	35	35	35	35	35	35	
Water pump (accessory)	Kw	0,25	0,25	0,25	0,25	0,37	0,37	
Water pump input current	A	2,1	2,1	2,1	2,1	3	3	
Water pump available static pressure	kPa	48	43	28	28	105	135	
Expansion vessel (accessory)	lt.	2	2	2	2	2	2	
Lenght (Standard version)	mm	700	700	700	700	700	700	
Width (Standard version)	mm	570	570	570	570	570	570	
Height (Standard version)	mm	850	850	850	850	850	850	
Weight (Standard version)	Kg	75	80	87	95	110	118	
Lenght (A1 version)	mm	635	635	635	635	635	635	
Width (A1 version)	mm	1004	1004	1004	1004	1004	1004	
Height (A1 version)	mm	1283	1283	1283	1283	1283	1283	
Weight (A1 version)	Kg	93	98	105	113	128	136	

Performances are referred to the following conditions:

Cooling: Evaporator water temperature in/out 12/7 °C;

* Condenser water inlet temperature 15°C (unit complete with pressostatic valve)

** Condenser water temperature 30/35°C (unit without pressostatic valve)

Heating: Condenser water temperature in/out 40/45°C; Evaporator water temperature in/out 15/10°C.

(1): Sound power level according to ISO 3746.

(2): Sound pressure level measured at 1 mt from the unit in free field conditions direction factor Q=2 according to ISO 3746

**WATER CHILLERS AND HEAT PUMPS
WSK
TECHNICAL DATA**

Mod.		20	25	30	35	40
Refrigerant		R407C	R407C	R407C	R407C	R407C
Cooling capacity	Kw	20,7	25,3	29,3	35,9	43,9
Compressor input power	Kw	6,0	7,2	8,2	10,2	12,3
Evaporator water flow	l/h	3560	4350	5040	6170	7550
Evaporator pressure drops	Kpa	32,0	36,0	38,0	36,04	39,0
Condenser water consumption*	l/h	1150	1400	1610	1980	2420
Condenser pressure drops*	Kpa	28	35	25	30	37
Condenser water flow**	l/h	4600	5600	6450	7930	9670
Condenser pressure drops**	Kpa	42	45	30	38	45
Heating capacity	Kw	27,3	33,4	38,2	47,0	57,3
Compressor input power	Kw	6,4	7,7	8,8	11,0	13,3
Condenser water flow	l/h	4700	5750	6570	8070	9860
Condenser pressure drops	Kpa	46	49	42	45	38
Evaporator water consumption	l/h	3595	4420	5060	6200	7570
Evaporator pressure drops	Kpa	44	45	46	44	35
Nominal input current (A version)	A	16,5	18,6	22,5	25,4	30,4
Peak current	A	102,0	126,0	131,5	171,5	202,5
Maximum input current	A	18,1	21,0	25,5	30,1	32,3
Power supply	V/Ph/Hz	400/ 3+N /50				
Compressor	Tipo	Scroll				
	n°	1	1	1	1	1
Sound power level ⁽¹⁾	dB(A)	60	60	62	64	64
Sound pressure level ⁽²⁾	dB(A)	52	52	54	56	56
Water tank capacity (Version A1)	lt.	60	60	60	60	60
Water pump (accessory)	Kw	0,37	0,37	0,55	0,55	0,55
Water pump input current	A	3	3	4,5	4,5	4,5
Water pump available static pressure	kPa	128	121	133	116	95
Expansion vessel (accessory)	lt.	2	2	5	5	5
Lenght (Standard version)	mm	700	700	700	700	700
Width (Standard version)	mm	570	570	570	570	570
Height (Standard version)	mm	850	850	850	850	850
Weight (Standard version)	kg	130	138	144	152	164
Lenght (A1 version)	mm	635	635	635	635	635
Width (A1 version)	mm	1004	1004	1004	1004	1004
Height (A1 version)	mm	1283	1283	1283	1283	1283
Weight (A1 version)	kg	145	159	170	185	195

Performances are referred to the following conditions:

Cooling: Evaporator water temperature in/out 12/7 °C;

* Condenser water inlet temperature 15°C (unit complete with pressostatic valve)

** Condenser water temperature 30/35°C (unit without pressostatic valve)

Heating: Condenser water temperature in/out 40/45°C; Evaporator water temperature in/out 15/10°C.

(1): Sound power level according to ISO 3746.

(2): Sound pressure level measured at 1 mt from the unit in free field conditions direction factor Q=2 according to ISO 3746

**MOTO –EVAPORATING UNIT
WSK / EV
TECHNICAL DATA**

Mod.		04	05	07	09	13	15	
Refrigerant		R407C	R407C	R407C	R407C	R407C	R407C	
Cooling capacity	Kw	4,1	5,0	7,7	9,1	13,7	16,4	
Compressor input power	Kw	1,2	1,5	2,3	2,7	4,0	4,7	
Evaporator water flow	l/h	700	860	1320	1560	2360	2820	
Evaporator pressure drops	Kpa	17,0	12,0	24,0	26,0	28,0	32,0	
Nominal input current (A version)	A	11	13,5	18,6	21,7	12,0	13,0	
Peak current	A	38	50	79	103	15,0	15,0	
Maximum input current	A	13	14,4	20,3	26,1	69,0	77,0	
Power supply	V/Ph/Hz	230/1/50				400/3+N /50		
Compressor	tipo	Scroll						
	n°	1	1	1	1	1	1	
Sound power level ⁽¹⁾	dB(A)	50	51	52	52	54	54	
Sound pressure level ⁽²⁾	dB(A)	42	43	44	44	46	46	
Water tank capacity (Version A1)	lt.	35	35	35	35	35	35	
Water pump (accessory)	Kw	0,25	0,25	0,25	0,25	0,37	0,37	
Water pump input current	A	2,1	2,1	2,1	2,1	3	3	
Water pump available static pressure	kPa	48	43	28	28	105	135	
Expansion vessel (accessory)	lt.	2	2	2	2	2	2	
Lenght (Standard version)	mm	700	700	700	700	700	700	
Width (Standard version)	mm	570	570	570	570	570	570	
Height (Standard version)	mm	850	850	850	850	850	850	
Weight (Standard version)	Kg	70	75	82	90	105	113	
Lenght (A1 version)	mm	635	635	635	635	635	635	
Width (A1 version)	mm	1004	1004	1004	1004	1004	1004	
Height (A1 version)	mm	1283	1283	1283	1283	1283	1283	
Weight (A1 version)	Kg	85	90	93	107	120	125	

Performances are referred to the following conditions:

Cooling: Evaporator water temperature in/out 12/7 °C; Condensing temperature 50°C.

(1): Sound power level according to ISO 3746.

(2): Sound pressure level measured at 1 mt from the unit in free field conditions direction factor Q=2 according to ISO 3746

**MOTO –EVAPORATING UNIT
WSK / EV
TECHNICAL DATA**

Mod.		20	25	30	35	40
Refrigerant		R407C	R407C	R407C	R407C	R407C
Cooling capacity	Kw	20,7	25,3	29,3	35,9	43,9
Compressor input power	Kw	6,0	7,2	8,2	10,2	12,3
Evaporator water flow	l/h	3560	4350	5040	6170	7550
Evaporator pressure drops	Kpa	32,0	36,0	38,0	36,04	39,0
Nominal input current (A version)	A	16,5	18,6	22,5	25,4	30,4
Peak current	A	102,0	126,0	131,5	171,5	202,5
Maximum input current	A	18,1	21,0	25,5	30,1	32,3
Power supply	V/Ph/Hz	400/ 3+N /50				
Compressor	Type	Scroll				
	n°	1	1	1	1	1
Sound power level ⁽¹⁾	dB(A)	60	60	62	64	64
Sound pressure level ⁽²⁾	dB(A)	52	52	54	56	56
Water tank capacity (Version A1)	lt.	60	60	60	60	60
Water pump (accessory)	Kw	0,37	0,37	0,55	0,55	0,55
Water pump input current	A	3	3	4,5	4,5	4,5
Water pump available static pressure	kPa	128	121	133	116	95
Expansion vessel (accessory)	lt.	2	2	5	5	5
Lenght (Standard version)	mm	700	700	700	700	700
Width (Standard version)	mm	570	570	570	570	570
Height (Standard version)	mm	850	850	850	850	850
Weight (Standard version)	kg	120	128	134	140	153
Lenght (A1 version)	mm	635	635	635	635	635
Width (A1 version)	mm	1004	1004	1004	1004	1004
Height (A1 version)	mm	1283	1283	1283	1283	1283
Weight (A1 version)	kg	135	142	165	170	180

Performances are referred to the following conditions:

Cooling: Evaporator water temperature in/out 12/7 °C; Condensing temperature 50°C.

(1): Sound power level according to ISO 3746.

(2): Sound pressure level measured at 1 mt from the unit in free field conditions direction factor Q=2 according to ISO 3746

WSK
COOLING CAPACITY AND COMPRESSOR INPUT POWER

Mod.	TWUE (°C)	PF (kW)						PA (kW)					
		TWIC (°C)						TWIC (°C)					
		15	20	25	30	35	40	15	20	25	30	35	40
04	-1	3,7	3,5	3,2	3,0	2,6	2,3	0,8	1,0	1,1	1,3	1,5	1,7
	1	4,0	3,8	3,5	3,2	2,9	2,6	0,8	1,0	1,1	1,3	1,5	1,7
	3	4,3	4,1	3,8	3,5	3,2	2,8	0,8	1,0	1,1	1,2	1,4	1,7
	5	4,7	4,4	4,1	3,8	3,5	3,1	0,8	1,0	1,1	1,2	1,4	1,7
	7	5,0	4,8	4,5	4,1	3,8	3,4	0,9	1,0	1,1	1,2	1,4	1,7
	9	6,8	6,4	6,0	5,6	5,2	4,7	0,8	1,0	1,1	1,2	1,4	1,6
	11	5,9	5,6	5,2	4,9	4,5	4,0	0,9	1,0	1,1	1,2	1,4	1,7

Mod.	TWUE (°C)	PF (kW)						PA (kW)					
		TWIC (°C)						TWIC (°C)					
		15	20	25	30	35	40	15	20	25	30	35	40
05	-1	4,4	4,1	3,8	3,5	3,2	2,8	1,0	1,2	1,3	1,6	1,8	2,1
	1	4,8	4,5	4,2	3,8	3,5	3,1	1,0	1,2	1,3	1,6	1,8	2,1
	3	5,2	4,9	4,6	4,2	3,8	3,4	1,0	1,1	1,3	1,6	1,8	2,1
	5	5,6	5,3	5,0	4,6	4,2	3,8	1,0	1,1	1,3	1,5	1,8	2,1
	7	6,1	5,8	5,4	5,0	4,6	4,1	1,0	1,1	1,3	1,5	1,8	2,1
	9	6,6	6,3	5,9	5,5	5,0	4,5	1,0	1,1	1,3	1,5	1,8	2,1
	11	7,1	6,8	6,4	5,9	5,4	4,9	1,0	1,1	1,3	1,5	1,8	2,1

Mod.	TWUE (°C)	PF (kW)						PA (kW)					
		TWIC (°C)						TWIC (°C)					
		15	20	25	30	35	40	15	20	25	30	35	40
07	-1	6,7	6,3	5,9	5,4	4,9	4,4	1,5	1,7	2,0	2,4	2,7	3,2
	1	7,3	6,9	6,4	5,9	5,4	4,8	1,5	1,7	2,0	2,4	2,7	3,2
	3	8,0	7,6	7,1	6,5	5,9	5,3	1,5	1,7	2,0	2,4	2,7	3,2
	5	8,7	8,2	7,7	7,1	6,5	5,8	1,5	1,7	2,0	2,3	2,7	3,2
	7	9,4	8,9	8,4	7,7	7,1	6,4	1,5	1,7	2,0	2,3	2,7	3,2
	9	10,2	9,7	9,1	8,4	7,7	7,0	1,5	1,7	2,0	2,3	2,7	3,1
	11	11,0	10,4	9,8	9,1	8,4	7,6	1,5	1,7	2,0	2,3	2,7	3,1

Mod.	TWUE (°C)	PF (kW)						PA (kW)					
		TWIC (°C)						TWIC (°C)					
		15	20	25	30	35	40	15	20	25	30	35	40
09	-1	7,9	7,4	6,9	6,3	5,7	5,1	1,8	2,0	2,4	2,8	3,2	3,7
	1	8,6	8,1	7,6	7,0	6,3	5,7	1,7	2,0	2,4	2,8	3,2	3,7
	3	9,4	8,9	8,3	7,6	7,0	6,2	1,7	2,0	2,4	2,8	3,2	3,7
	5	10,2	9,7	9,0	8,4	7,6	6,8	1,7	2,0	2,4	2,7	3,2	3,7
	7	11,1	10,5	9,8	9,1	8,3	7,5	1,7	2,0	2,4	2,7	3,2	3,7
	9	11,9	11,4	10,7	9,9	9,1	8,2	1,7	2,0	2,3	2,7	3,2	3,7
	11	12,9	12,3	11,6	10,7	9,9	8,9	1,7	2,0	2,3	2,7	3,1	3,6

TWUE: Evaporator outlet water temperature (°C) (Dt=5°C)
 TWIC: Condenser water inlet temperature (°C) (Dt=5°C)
 PA: Compressors input power (Kw)
 PF: Cooling capacity (Kw)

**WSK
COOLING CAPACITY AND COMPRESSOR INPUT POWER**

Mod.	TWUE (°C)	PF (kW)						PA (kW)					
		TWIC (°C)						TWIC (°C)					
		15	20	25	30	35	40	15	20	25	30	35	40
13	-1	11,9	11,2	10,4	9,5	8,7	7,8	2,6	3,0	3,5	4,0	4,5	5,1
	1	13,0	12,2	11,4	10,5	9,6	8,6	2,6	3,0	3,5	4,0	4,5	5,1
	3	14,2	13,4	12,5	11,5	10,5	9,5	2,6	3,0	3,5	4,0	4,6	5,2
	5	15,4	14,6	13,6	12,6	11,5	10,4	2,6	3,0	3,5	4,0	4,6	5,2
	7	16,8	15,9	14,8	13,7	12,6	11,4	2,7	3,0	3,5	4,0	4,6	5,2
	9	18,2	17,2	16,1	15,0	13,7	12,4	2,7	3,1	3,5	4,0	4,6	5,2
	11	19,7	18,6	17,5	16,3	14,9	13,6	2,7	3,1	3,5	4,0	4,6	5,3

Mod.	TWUE (°C)	PF (kW)						PA (kW)					
		TWIC (°C)						TWIC (°C)					
		15	20	25	30	35	40	15	20	25	30	35	40
15	-1	14,6	13,8	12,8	11,6	10,5	9,4	3,0	3,5	4,0	4,6	5,3	6,0
	1	15,9	15,0	13,9	12,8	11,6	10,5	3,0	3,5	4,0	4,6	5,3	6,1
	3	17,2	16,3	15,1	14,0	12,7	11,6	3,1	3,5	4,0	4,6	5,3	6,1
	5	18,7	17,6	16,4	15,2	13,9	12,7	3,1	3,5	4,0	4,6	5,3	6,1
	7	20,2	19,1	17,8	16,4	15,2	13,9	3,1	3,5	4,0	4,7	5,3	6,1
	9	21,8	20,6	19,2	17,8	16,5	15,1	3,1	3,5	4,0	4,7	5,3	6,1
	11	23,6	22,2	20,7	19,3	17,8	16,4	3,1	3,5	4,1	4,7	5,4	6,1

Mod.	TWUE (°C)	PF (kW)						PA (kW)					
		TWIC (°C)						TWIC (°C)					
		15	20	25	30	35	40	15	20	25	30	35	40
20	-1	18,2	17,0	15,8	14,6	13,4	12,3	4,0	4,6	5,2	6,0	6,9	7,9
	1	19,9	18,5	17,2	16,0	14,8	13,6	4,0	4,5	5,2	6,0	6,9	8,0
	3	21,6	20,2	18,8	17,5	16,1	14,9	4,0	4,5	5,2	6,0	7,0	8,0
	5	23,5	22,0	20,5	19,1	17,6	16,2	4,0	4,5	5,2	6,0	7,0	8,0
	7	25,5	23,9	22,3	20,7	19,2	17,7	4,0	4,5	5,2	6,0	7,0	8,1
	9	27,6	25,9	24,2	22,5	20,9	19,3	4,0	4,5	5,1	6,0	6,9	8,1
	11	29,8	28,0	26,2	24,4	22,7	20,9	4,1	4,5	5,1	5,9	6,9	8,1

Mod.	TWUE (°C)	PF (kW)						PA (kW)					
		TWIC (°C)						TWIC (°C)					
		15	20	25	30	35	40	15	20	25	30	35	40
25	-1	22,4	21,0	19,6	18,2	16,7	15,3	4,8	5,5	6,3	7,2	8,2	9,3
	1	24,3	22,8	21,3	19,8	18,2	16,7	4,8	5,5	6,3	7,2	8,2	9,3
	3	26,3	24,7	23,1	21,5	19,9	18,2	4,8	5,5	6,3	7,2	8,2	9,4
	5	28,5	26,8	25,1	23,4	21,6	19,8	4,8	5,5	6,3	7,2	8,2	9,4
	7	30,7	29,0	27,1	25,3	23,4	21,5	4,7	5,4	6,2	7,2	8,2	9,4
	9	33,2	31,3	29,3	27,4	25,4	23,4	4,7	5,4	6,2	7,2	8,2	9,4
	11	35,7	33,7	31,7	29,6	27,5	25,3	4,7	5,4	6,2	7,2	8,2	9,5

TWUE: Evaporator outlet water temperature (°C) (Dt=5°C)
TWIC: Condenser water inlet temperature (°C) (Dt=5°C)
PA: Compressors input power (Kw)
PF: Cooling capacity (Kw)

**WSK
COOLING CAPACITY AND COMPRESSOR INPUT POWER**

Mod.	TWUE (°C)	PF (kW)						PA (kW)					
		TWIC (°C)						TWIC (°C)					
		15	20	25	30	35	40	15	20	25	30	35	40
30	-1	26,0	24,5	22,8	21,1	19,4	17,6	5,4	6,2	7,2	8,2	9,3	10,5
	1	28,2	26,5	24,8	23,0	21,2	19,3	5,4	6,2	7,1	8,2	9,3	10,6
	3	30,5	28,7	26,9	25,0	23,0	21,0	5,4	6,2	7,1	8,2	9,4	10,7
	5	33,0	31,1	29,1	27,1	25,0	22,9	5,4	6,2	7,1	8,2	9,4	10,7
	7	35,6	33,6	31,5	29,3	27,1	24,9	5,3	6,1	7,1	8,2	9,4	10,8
	9	38,3	36,2	34,0	31,7	29,4	27,0	5,3	6,1	7,1	8,2	9,4	10,8
	11	41,2	39,0	36,6	34,2	31,7	29,2	5,3	6,1	7,1	8,2	9,4	10,8

Mod.	TWUE (°C)	PF (kW)						PA (kW)					
		TWIC (°C)						TWIC (°C)					
		15	20	25	30	35	40	15	20	25	30	35	40
35	-1	32,1	30,1	28,1	26,0	23,9	21,7	6,8	7,7	8,9	10,2	11,7	13,3
	1	34,7	32,6	30,5	28,3	26,0	23,7	6,8	7,7	8,9	10,2	11,7	13,4
	3	37,6	35,3	33,0	30,7	28,2	25,8	6,8	7,7	8,9	10,2	11,8	13,5
	5	40,6	38,2	35,8	33,2	30,7	28,0	6,8	7,8	8,9	10,2	11,8	13,5
	7	43,8	41,3	38,7	35,9	33,2	30,4	6,9	7,8	8,9	10,2	11,8	13,6
	9	47,2	44,5	41,7	38,9	36,0	33,0	6,9	7,8	8,9	10,3	11,8	13,6
	11	50,8	47,9	45,0	42,0	38,9	35,7	7,0	7,8	8,9	10,3	11,8	13,7

Mod.	TWUE (°C)	PF (kW)						PA (kW)					
		TWIC (°C)						TWIC (°C)					
		15	20	25	30	35	40	15	20	25	30	35	40
40	-1	39,0	36,7	34,2	31,8	29,2	26,6	8,1	9,3	10,7	12,4	14,2	16,1
	1	42,3	39,8	37,2	34,5	31,8	29,0	8,1	9,3	10,7	12,4	14,2	16,2
	3	45,7	43,1	40,3	37,5	34,6	31,6	8,1	9,3	10,7	12,4	14,3	16,4
	5	49,4	46,6	43,6	40,6	37,6	34,4	8,2	9,2	10,7	12,3	14,3	16,4
	7	53,3	50,3	47,2	43,9	40,7	37,3	8,2	9,3	10,6	12,3	14,3	16,5
	9	57,4	54,2	50,9	47,5	44,0	40,5	8,4	9,3	10,6	12,3	14,3	16,5
	11	61,8	58,4	54,9	51,3	47,6	43,8	8,5	9,4	10,6	12,3	14,2	16,5

TWUE: Evaporator outlet water temperature (°C) (Dt=5°C)
TWIC: Condenser water inlet temperature (°C) (Dt=5°C)
PA: Compressors input power (Kw)
PF: Cooling capacity (Kw)

**WSK / HP
HEATING CAPACITY AND COMPRESSOR INPUT POWER**

WSK 04/HP												
TWIE	PH (kW)					PA (kW)						
	TWUC					TWUC						
	30	35	40	45	50	30	35	40	45	50		
8	4,7	4,6	4,5	4,4	4,3	1,0	1,1	1,2	1,3	1,5		
10	5,0	4,9	4,8	4,7	4,6	1,0	1,1	1,2	1,3	1,5		
15	5,9	5,8	5,6	5,5	5,3	1,0	1,1	1,2	1,3	1,5		
20	6,9	6,7	6,5	6,4	6,2	1,0	1,1	1,2	1,3	1,5		

WSK 05 /HP												
TWIE	PH (kW)					PA (kW)						
	TWUC					TWUC						
	30	35	40	45	50	30	35	40	45	50		
8	5,6	5,5	5,4	5,3	5,3	1,2	1,3	1,5	1,7	1,2		
10	6,0	5,9	5,8	5,7	5,6	1,1	1,3	1,5	1,7	1,1		
15	7,2	7,0	6,8	6,7	6,5	1,1	1,3	1,5	1,7	1,1		
20	8,4	8,2	8,0	7,8	7,6	1,1	1,3	1,4	1,6	1,1		

WSK 07/HP												
TWIE	PH (kW)					PA (kW)						
	TWUC					TWUC						
	30	35	40	45	50	30	35	40	45	50		
8	8,7	8,5	8,4	8,2	8,1	1,7	2,0	2,2	2,5	2,9		
10	9,3	9,1	8,9	8,8	8,6	1,7	2,0	2,2	2,5	2,9		
15	11,0	10,8	10,4	10,3	10,0	1,7	2,0	2,2	2,5	2,9		
20	13,0	12,7	12,3	12,0	11,6	1,7	1,9	2,2	2,5	2,8		

WSK 09/HP												
TWIE	PH (kW)					PA (kW)						
	TWUC					TWUC						
	30	35	40	45	50	30	35	40	45	50		
8	10,2	10,0	9,8	9,6	9,5	2,0	2,3	2,6	3,0	3,4		
10	10,9	10,7	10,5	10,3	10,1	2,0	2,3	2,6	3,0	3,4		
15	12,9	12,7	12,2	12,0	11,7	2,0	2,3	2,6	2,9	3,3		
20	15,2	14,9	14,5	14,1	13,6	2,0	2,3	2,6	2,9	3,3		

WSK 13/HP												
TWIE	PH (kW)					PA (kW)						
	TWUC					TWUC						
	30	35	40	45	50	30	35	40	45	50		
8	15,3	14,9	14,6	14,3	14,0	3,0	3,4	3,8	4,2	4,7		
10	16,4	16,0	15,7	15,3	14,9	3,0	3,4	3,8	4,3	4,8		
15	19,6	19,1	18,4	18,0	17,5	3,1	3,4	3,8	4,3	4,8		
20	23,2	22,6	21,9	21,2	20,6	3,1	3,5	3,9	4,3	4,8		

TWUC: Condenser outlet water temperature (°C) (Dt=5°C)
TWIE: Evaporator inlet water temperature (°C) (Dt=5°C)
PA: Compressors input power (Kw)
PH: Heating capacity (Kw)

**WSK / HP
HEATING CAPACITY AND COMPRESSOR INPUT POWER**

WSK 15/HP												
TWIE	PH (kW)					PA (kW)						
	TWUC					TWUC						
	30	35	40	45	50	30	35	40	45	50		
8	18,5	18,0	17,6	17,2	16,8	3,5	3,9	4,4	5,0	5,5		
10	19,8	19,3	18,8	18,3	17,9	3,5	3,9	4,4	5,0	5,6		
15	23,3	22,7	22,0	21,7	21,0	3,5	4,0	4,4	5,0	5,6		
20	27,4	26,6	25,7	25,0	24,3	3,5	4,0	4,4	5,0	5,6		

WSK 20/HP												
TWIE	PH (kW)					PA (kW)						
	TWUC					TWUC						
	30	35	40	45	50	30	35	40	45	50		
8	23,1	22,6	22,1	21,8	21,6	4,5	5,1	5,7	6,5	7,3		
10	24,7	24,1	23,7	23,3	23,0	4,5	5,1	5,7	6,5	7,3		
15	29,4	28,5	27,8	27,3	26,8	4,5	5,0	5,7	6,4	7,3		
20	34,8	33,7	32,7	31,9	31,2	4,5	5,0	5,6	6,4	7,3		

WSK 25/HP												
TWIE	PH (kW)					PA (kW)						
	TWUC					TWUC						
	30	35	40	45	50	30	35	40	45	50		
8	28,3	27,7	27,1	26,7	26,3	5,5	6,1	6,9	7,7	8,6		
10	30,2	29,5	28,9	28,4	27,9	5,5	6,1	6,9	7,7	8,6		
15	35,5	34,6	33,8	33,4	32,4	5,4	6,1	6,9	7,7	8,6		
20	41,7	40,6	39,5	38,5	37,6	5,4	6,1	6,8	7,7	8,6		

WSK 30/HP												
TWIE	PH (kW)					PA (kW)						
	TWUC					TWUC						
	30	35	40	45	50	30	35	40	45	50		
8	32,8	32,1	31,4	30,8	30,3	6,2	7,0	7,8	8,7	9,7		
10	34,9	34,2	33,5	32,8	32,2	6,2	7,0	7,8	8,8	9,8		
15	41,0	40,0	39,0	38,2	37,3	6,1	6,9	7,8	8,8	9,9		
20	48,0	46,7	45,5	44,3	43,2	6,1	6,9	7,7	8,7	9,9		

WSK 35/HP												
TWIE	PH (kW)					PA (kW)						
	TWUC					TWUC						
	30	35	40	45	50	30	35	40	45	50		
8	40,4	39,5	38,7	38,1	37,5	7,7	8,7	9,7	10,9	12,3		
10	43,1	42,1	41,2	40,4	39,7	7,7	8,7	9,8	11,0	12,3		
15	50,6	49,3	48,1	47,0	46,0	7,8	8,7	9,8	11,0	12,4		
20	59,4	57,7	56,1	54,6	53,3	7,9	8,8	9,8	11,0	12,4		

WSK 40/HP												
TWIE	PH (kW)					PA (kW)						
	TWUC					TWUC						
	30	35	40	45	50	30	35	40	45	50		
8	49,0	48,1	47,2	46,5	45,8	9,3	10,5	11,8	13,3	14,9		
10	52,3	51,2	50,2	49,4	48,6	9,3	10,4	11,8	13,3	15,0		
15	61,5	59,9	58,6	57,3	56,2	9,3	10,4	11,7	13,3	15,0		
20	72,3	70,2	68,2	66,5	65,0	9,5	10,5	11,7	13,2	14,9		

TWUC: Condenser outlet water temperature (°C) (Dt=5°C)
TWIE: Evaporator inlet water temperature (°C) (Dt=5°C)
PA: Compressors input power (Kw)
PH: Heating capacity (Kw)

**WSK / EV (MOTOEVAPORATING UNITS)
COOLING CAPACITY AND COMPRESSOR INPUT POWER**

Mod.	TWUE (°C)	PF (kW)						PA (kW)					
		TC (°C)						TC (°C)					
		35	40	45	50	55	60	35	40	45	50	55	60
04	-1	3,7	3,5	3,2	3,0	2,6	2,3	0,8	1,0	1,1	1,3	1,5	1,7
	1	4,0	3,8	3,5	3,2	2,9	2,6	0,8	1,0	1,1	1,3	1,5	1,7
	3	4,3	4,1	3,8	3,5	3,2	2,8	0,8	1,0	1,1	1,2	1,4	1,7
	5	4,7	4,4	4,1	3,8	3,5	3,1	0,8	1,0	1,1	1,2	1,4	1,7
	7	5,0	4,8	4,5	4,1	3,8	3,4	0,9	1,0	1,1	1,2	1,4	1,7
	9	6,8	6,4	6,0	5,6	5,2	4,7	0,8	1,0	1,1	1,2	1,4	1,6
	11	5,9	5,6	5,2	4,9	4,5	4,0	0,9	1,0	1,1	1,2	1,4	1,7

Mod.	TWUE (°C)	PF (kW)						PA (kW)					
		TC (°C)						TC (°C)					
		35	40	45	50	55	60	35	40	45	50	55	60
05	-1	4,4	4,1	3,8	3,5	3,2	2,8	1,0	1,2	1,3	1,6	1,8	2,1
	1	4,8	4,5	4,2	3,8	3,5	3,1	1,0	1,2	1,3	1,6	1,8	2,1
	3	5,2	4,9	4,6	4,2	3,8	3,4	1,0	1,1	1,3	1,6	1,8	2,1
	5	5,6	5,3	5,0	4,6	4,2	3,8	1,0	1,1	1,3	1,5	1,8	2,1
	7	6,1	5,8	5,4	5,0	4,6	4,1	1,0	1,1	1,3	1,5	1,8	2,1
	9	6,6	6,3	5,9	5,5	5,0	4,5	1,0	1,1	1,3	1,5	1,8	2,1
	11	7,1	6,8	6,4	5,9	5,4	4,9	1,0	1,1	1,3	1,5	1,8	2,1

Mod.	TWUE (°C)	PF (kW)						PA (kW)					
		TC (°C)						TC (°C)					
		35	40	45	50	55	60	35	40	45	50	55	60
07	-1	6,7	6,3	5,9	5,4	4,9	4,4	1,5	1,7	2,0	2,4	2,7	3,2
	1	7,3	6,9	6,4	5,9	5,4	4,8	1,5	1,7	2,0	2,4	2,7	3,2
	3	8,0	7,6	7,1	6,5	5,9	5,3	1,5	1,7	2,0	2,4	2,7	3,2
	5	8,7	8,2	7,7	7,1	6,5	5,8	1,5	1,7	2,0	2,3	2,7	3,2
	7	9,4	8,9	8,4	7,7	7,1	6,4	1,5	1,7	2,0	2,3	2,7	3,2
	9	10,2	9,7	9,1	8,4	7,7	7,0	1,5	1,7	2,0	2,3	2,7	3,1
	11	11,0	10,4	9,8	9,1	8,4	7,6	1,5	1,7	2,0	2,3	2,7	3,1

Mod.	TWUE (°C)	PF (kW)						PA (kW)					
		TC (°C)						TC (°C)					
		35	40	45	50	55	60	35	40	45	50	55	60
09	-1	7,9	7,4	6,9	6,3	5,7	5,1	1,8	2,0	2,4	2,8	3,2	3,7
	1	8,6	8,1	7,6	7,0	6,3	5,7	1,7	2,0	2,4	2,8	3,2	3,7
	3	9,4	8,9	8,3	7,6	7,0	6,2	1,7	2,0	2,4	2,8	3,2	3,7
	5	10,2	9,7	9,0	8,4	7,6	6,8	1,7	2,0	2,4	2,7	3,2	3,7
	7	11,1	10,5	9,8	9,1	8,3	7,5	1,7	2,0	2,4	2,7	3,2	3,7
	9	11,9	11,4	10,7	9,9	9,1	8,2	1,7	2,0	2,3	2,7	3,2	3,7
	11	12,9	12,3	11,6	10,7	9,9	8,9	1,7	2,0	2,3	2,7	3,1	3,6

TWUE: Evaporator outlet water temperature (°C) (Dt=5°C)
TC: Condensing temperature (°C)
PA: Compressors input power (Kw)
PF: Cooling capacity (Kw)

**WSK / EV (MOTOEVAPORATING UNITS)
COOLING CAPACITY AND COMPRESSOR INPUT POWER**

Mod.	TWUE (°C)	PF (kW)						PA (kW)					
		TC (°C)						TC (°C)					
		35	40	45	50	55	60	35	40	45	50	55	60
13	-1	11,9	11,2	10,4	9,5	8,7	7,8	2,6	3,0	3,5	4,0	4,5	5,1
	1	13,0	12,2	11,4	10,5	9,6	8,6	2,6	3,0	3,5	4,0	4,5	5,1
	3	14,2	13,4	12,5	11,5	10,5	9,5	2,6	3,0	3,5	4,0	4,6	5,2
	5	15,4	14,6	13,6	12,6	11,5	10,4	2,6	3,0	3,5	4,0	4,6	5,2
	7	16,8	15,9	14,8	13,7	12,6	11,4	2,7	3,0	3,5	4,0	4,6	5,2
	9	18,2	17,2	16,1	15,0	13,7	12,4	2,7	3,1	3,5	4,0	4,6	5,2
	11	19,7	18,6	17,5	16,3	14,9	13,6	2,7	3,1	3,5	4,0	4,6	5,3

Mod.	TWUE (°C)	PF (kW)						PA (kW)					
		TC (°C)						TC (°C)					
		35	40	45	50	55	60	35	40	45	50	55	60
15	-1	14,6	13,8	12,8	11,6	10,5	9,4	3,0	3,5	4,0	4,6	5,3	6,0
	1	15,9	15,0	13,9	12,8	11,6	10,5	3,0	3,5	4,0	4,6	5,3	6,1
	3	17,2	16,3	15,1	14,0	12,7	11,6	3,1	3,5	4,0	4,6	5,3	6,1
	5	18,7	17,6	16,4	15,2	13,9	12,7	3,1	3,5	4,0	4,6	5,3	6,1
	7	20,2	19,1	17,8	16,4	15,2	13,9	3,1	3,5	4,0	4,7	5,3	6,1
	9	21,8	20,6	19,2	17,8	16,5	15,1	3,1	3,5	4,0	4,7	5,3	6,1
	11	23,6	22,2	20,7	19,3	17,8	16,4	3,1	3,5	4,1	4,7	5,4	6,1

Mod.	TWUE (°C)	PF (kW)						PA (kW)					
		TC (°C)						TC (°C)					
		35	40	45	50	55	60	35	40	45	50	55	60
20	-1	18,2	17,0	15,8	14,6	13,4	12,3	4,0	4,6	5,2	6,0	6,9	7,9
	1	19,9	18,5	17,2	16,0	14,8	13,6	4,0	4,5	5,2	6,0	6,9	8,0
	3	21,6	20,2	18,8	17,5	16,1	14,9	4,0	4,5	5,2	6,0	7,0	8,0
	5	23,5	22,0	20,5	19,1	17,6	16,2	4,0	4,5	5,2	6,0	7,0	8,0
	7	25,5	23,9	22,3	20,7	19,2	17,7	4,0	4,5	5,2	6,0	7,0	8,1
	9	27,6	25,9	24,2	22,5	20,9	19,3	4,0	4,5	5,1	6,0	6,9	8,1
	11	29,8	28,0	26,2	24,4	22,7	20,9	4,1	4,5	5,1	5,9	6,9	8,1

Mod.	TWUE (°C)	PF (kW)						PA (kW)					
		TC (°C)						TC (°C)					
		35	40	45	50	55	60	35	40	45	50	55	60
25	-1	22,4	21,0	19,6	18,2	16,7	15,3	4,8	5,5	6,3	7,2	8,2	9,3
	1	24,3	22,8	21,3	19,8	18,2	16,7	4,8	5,5	6,3	7,2	8,2	9,3
	3	26,3	24,7	23,1	21,5	19,9	18,2	4,8	5,5	6,3	7,2	8,2	9,4
	5	28,5	26,8	25,1	23,4	21,6	19,8	4,8	5,5	6,3	7,2	8,2	9,4
	7	30,7	29,0	27,1	25,3	23,4	21,5	4,7	5,4	6,2	7,2	8,2	9,4
	9	33,2	31,3	29,3	27,4	25,4	23,4	4,7	5,4	6,2	7,2	8,2	9,4
	11	35,7	33,7	31,7	29,6	27,5	25,3	4,7	5,4	6,2	7,2	8,2	9,5

TWUE: Evaporator outlet water temperature (°C) (Dt=5°C)
TC: Condensing temperature (°C)
PA: Compressors input power (Kw)
PF: Cooling capacity (Kw)

**WSK / EV (MOTOEVAPORATING UNITS)
COOLING CAPACITY AND COMPRESSOR INPUT POWER**

Mod.	TWUE (°C)	PF (kW)						PA (kW)					
		TC (°C)						TC (°C)					
		35	40	45	50	55	60	35	40	45	50	55	60
30	-1	26,0	24,5	22,8	21,1	19,4	17,6	5,4	6,2	7,2	8,2	9,3	10,5
	1	28,2	26,5	24,8	23,0	21,2	19,3	5,4	6,2	7,1	8,2	9,3	10,6
	3	30,5	28,7	26,9	25,0	23,0	21,0	5,4	6,2	7,1	8,2	9,4	10,7
	5	33,0	31,1	29,1	27,1	25,0	22,9	5,4	6,2	7,1	8,2	9,4	10,7
	7	35,6	33,6	31,5	29,3	27,1	24,9	5,3	6,1	7,1	8,2	9,4	10,8
	9	38,3	36,2	34,0	31,7	29,4	27,0	5,3	6,1	7,1	8,2	9,4	10,8
	11	41,2	39,0	36,6	34,2	31,7	29,2	5,3	6,1	7,1	8,2	9,4	10,8

Mod.	TWUE (°C)	PF (kW)						PA (kW)					
		TC (°C)						TC (°C)					
		35	40	45	50	55	60	35	40	45	50	55	60
35	-1	32,1	30,1	28,1	26,0	23,9	21,7	6,8	7,7	8,9	10,2	11,7	13,3
	1	34,7	32,6	30,5	28,3	26,0	23,7	6,8	7,7	8,9	10,2	11,7	13,4
	3	37,6	35,3	33,0	30,7	28,2	25,8	6,8	7,7	8,9	10,2	11,8	13,5
	5	40,6	38,2	35,8	33,2	30,7	28,0	6,8	7,8	8,9	10,2	11,8	13,5
	7	43,8	41,3	38,7	35,9	33,2	30,4	6,9	7,8	8,9	10,2	11,8	13,6
	9	47,2	44,5	41,7	38,9	36,0	33,0	6,9	7,8	8,9	10,3	11,8	13,6
	11	50,8	47,9	45,0	42,0	38,9	35,7	7,0	7,8	8,9	10,3	11,8	13,7

Mod.	TWUE (°C)	PF (kW)						PA (kW)					
		TC (°C)						TC (°C)					
		35	40	45	50	55	60	35	40	45	50	55	60
40	-1	39,0	36,7	34,2	31,8	29,2	26,6	8,1	9,3	10,7	12,4	14,2	16,1
	1	42,3	39,8	37,2	34,5	31,8	29,0	8,1	9,3	10,7	12,4	14,2	16,2
	3	45,7	43,1	40,3	37,5	34,6	31,6	8,1	9,3	10,7	12,4	14,3	16,4
	5	49,4	46,6	43,6	40,6	37,6	34,4	8,2	9,2	10,7	12,3	14,3	16,4
	7	53,3	50,3	47,2	43,9	40,7	37,3	8,2	9,3	10,6	12,3	14,3	16,5
	9	57,4	54,2	50,9	47,5	44,0	40,5	8,4	9,3	10,6	12,3	14,3	16,5
	11	61,8	58,4	54,9	51,3	47,6	43,8	8,5	9,4	10,6	12,3	14,2	16,5

TWUE: Evaporator outlet water temperature (°C) (Dt=5°C)
TC: Condensing temperature (°C)
PA: Compressors input power (Kw)
PF: Cooling capacity (Kw)

EVAPORATOR PRESSURE DROPS

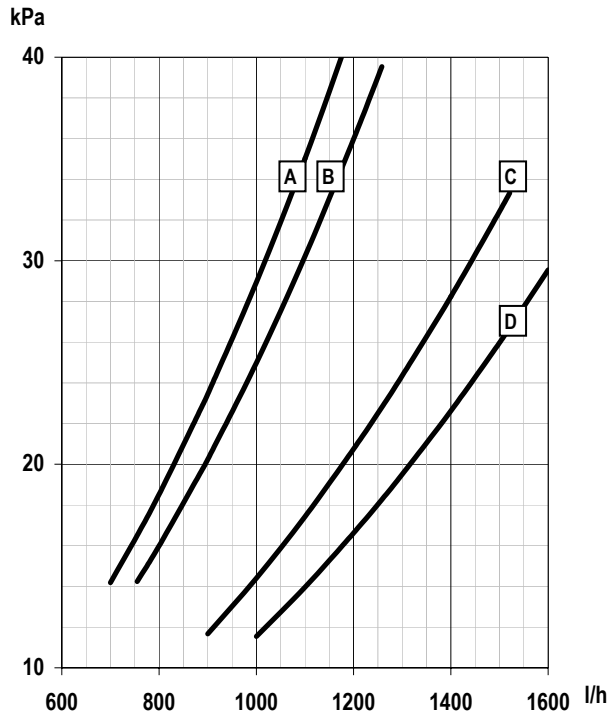

A: WSK 04 B: WSK 05 C: WSK 07 D: WSK 09

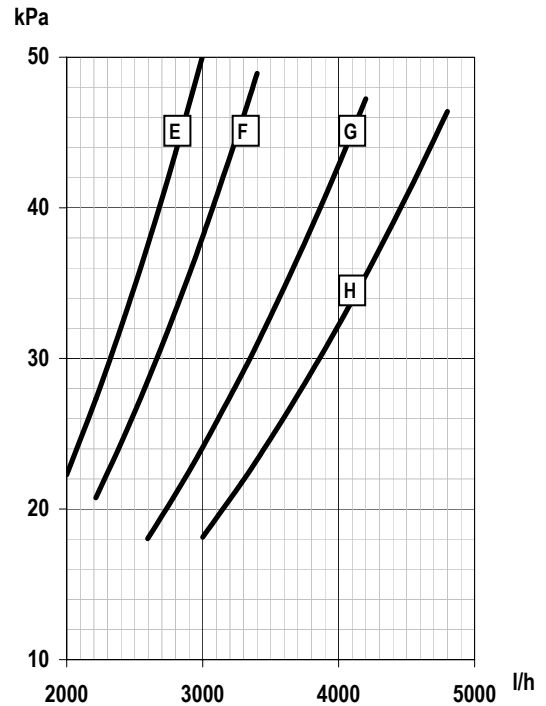

E: WSK 13 F: WSK 15 G: WSK 20 H: WSK 25

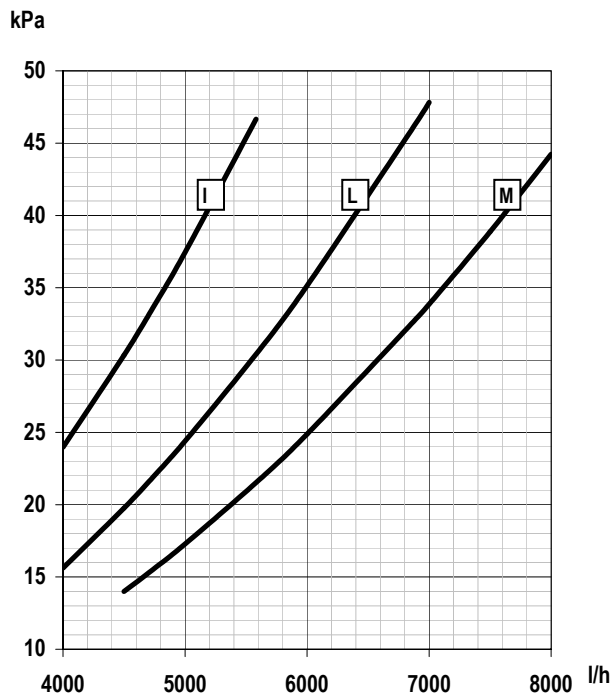

I: WSK 30 L: WSK 35 M: WSK 040

CONDENSER PRESSURE DROPS

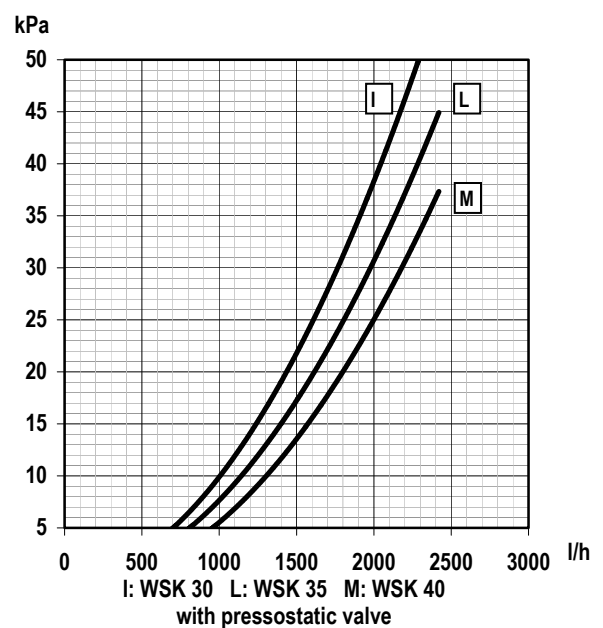
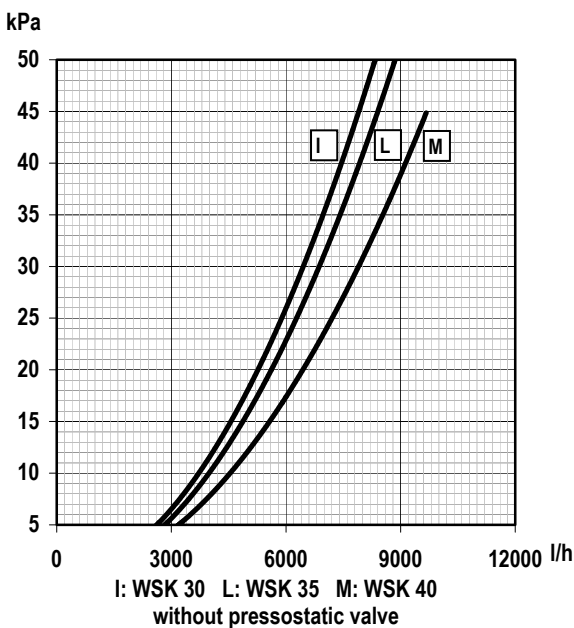
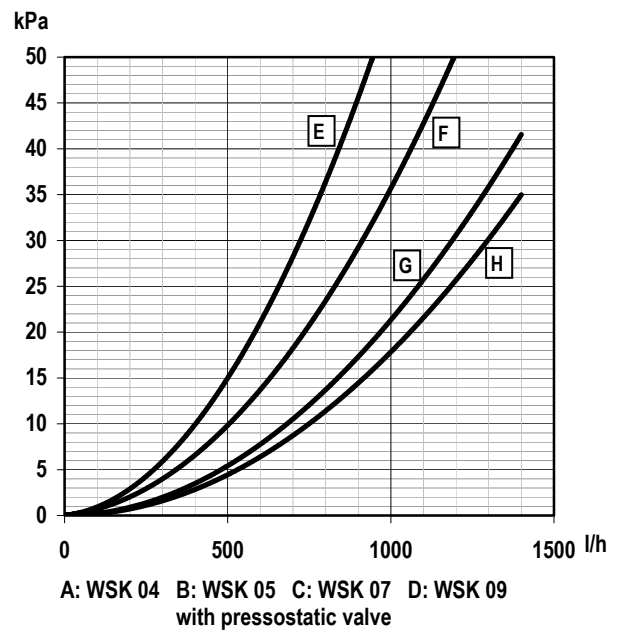
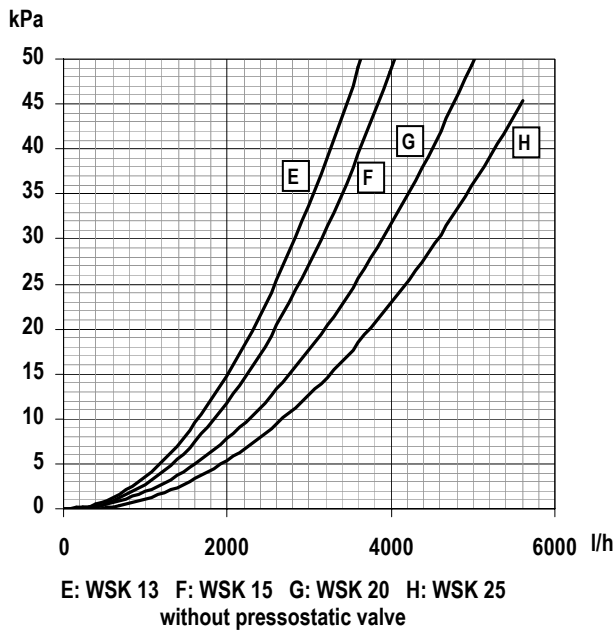
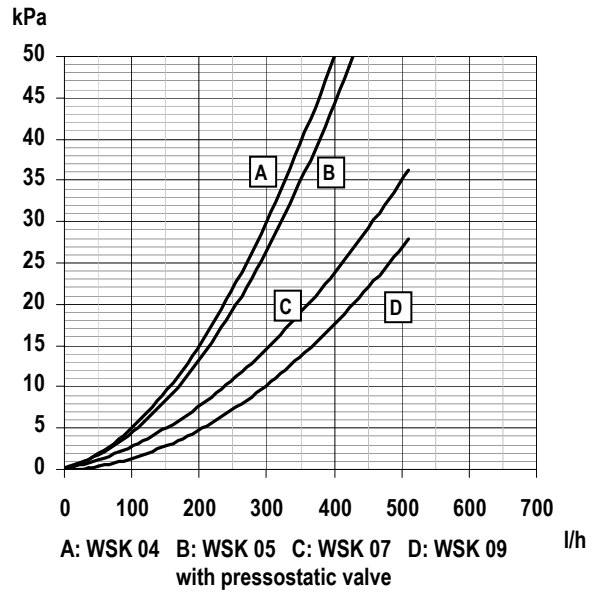
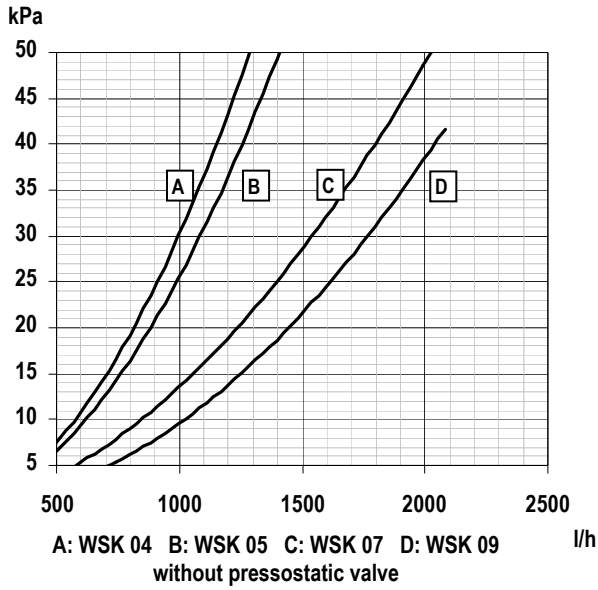

WATER PUMPS AVAILABLE STATIC PRESSURE

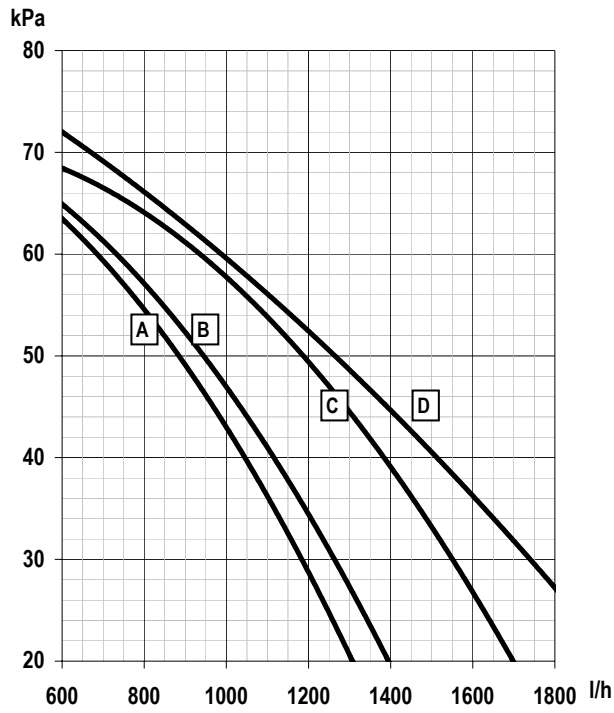

A: WSK 04 B: WSK 05 C: WSK 07 D: WSK 09

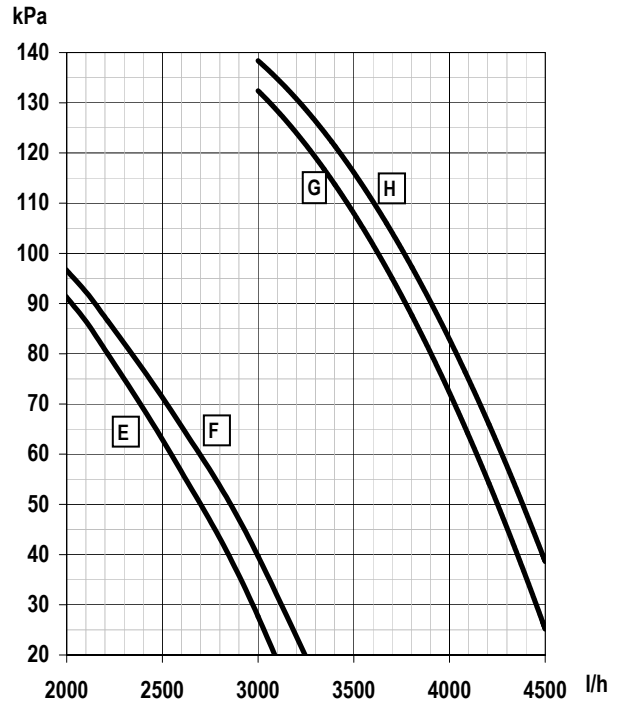

E: WSK 13 F: WSK 15 G: WSK 20 H: WSK 25

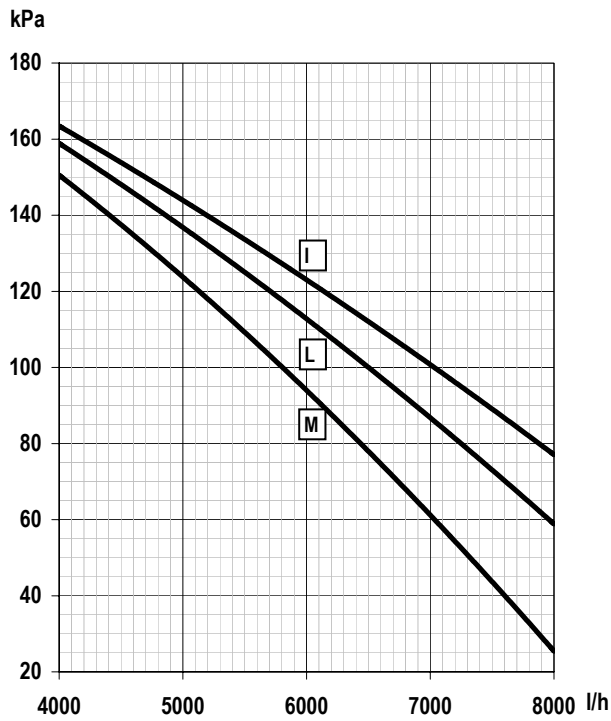

I: WSK 30 L: WSK 35 M: WSK 40

PARTIAL HEAT RECOVERY CAPACITY

Mod.		20	25	30	35	40
Partial heat recovery nominal capacity	kW	5,5	6,3	7,2	9	11,2
Water flow	l/h	950	1100	1240	1550	1930
Water pressure drops	kPa	15	18	16	19	25

The nominal value refers to an evaporator water in/out 12/7°C and condenser water in/out 30/35°C

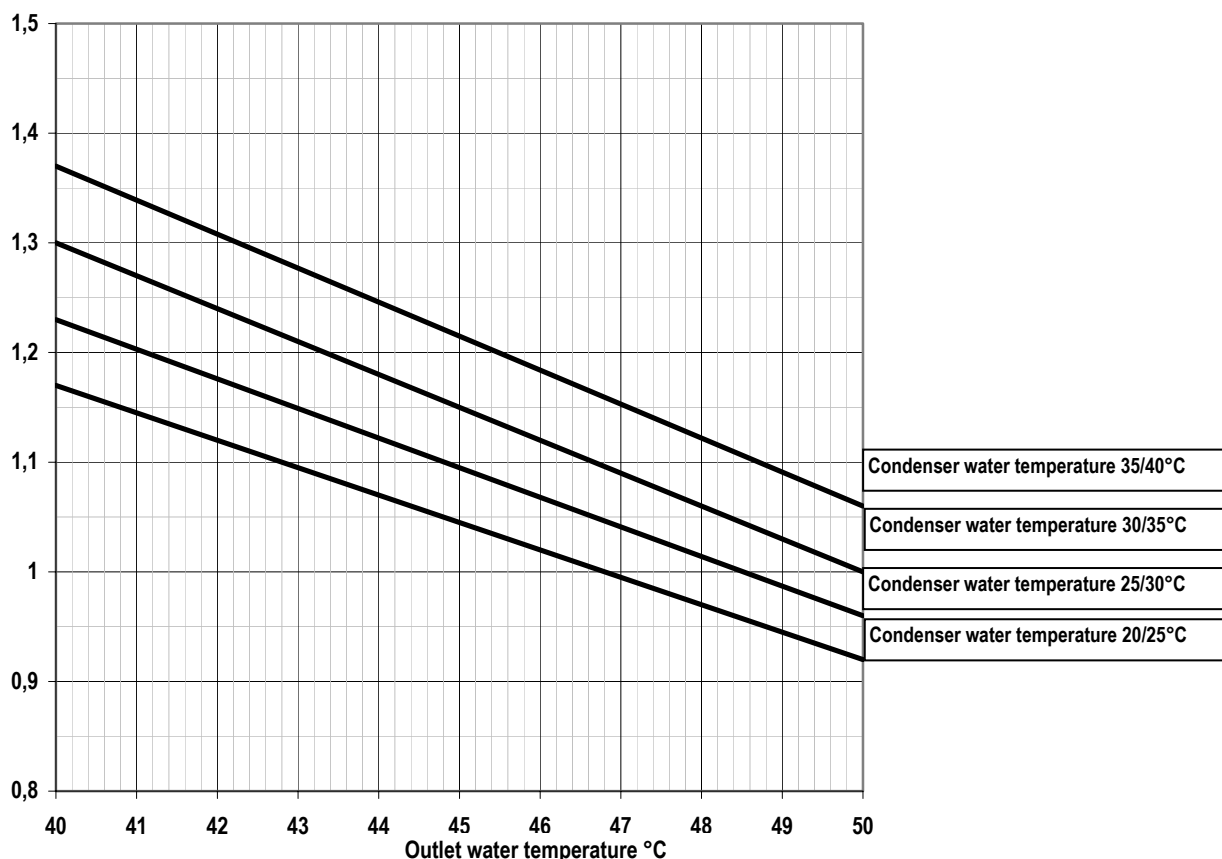

The heat recovery capacity in different conditions can be obtained multiplying the nominal capacity (See above), by the correction factor indicated in the table.



WARNING: the partial heat recovery can only work in cooling mode; in case of heat pump version it is necessary to intercept the heat recovery in heating mode, otherwise the unit can be damaged. The guarantee will not be valid in case the heat recovery is not intercepted

OPERATION LIMITS

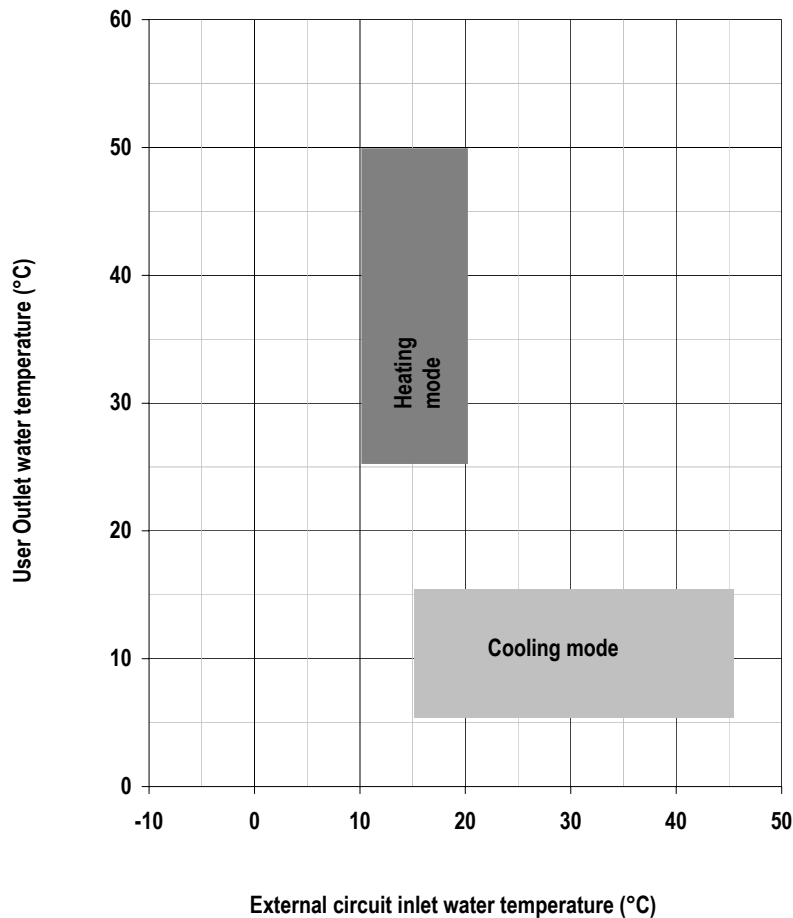

Heat exchanger water flow

The nominal water flow rate given by HIDROS is referred to a Dt of 5 °C. Maximum flow rate allowed is the one that presents a Dt of 3 °C: higher values may cause too high pressure drop. The minimum water flow rate allowed is the one presenting a Dt of 8 °C. Insufficient values cause too low evaporating temperatures with the action of safety devices which would stop the unit.

Evaporator water temperature (summer operation)

The minimum evaporator water outlet is 5 °C. The maximum evaporator water outlet is 15°C. In case of operation outside this range of temperatures please contact the company.

Condenser water temperature (summer operation)

The minimum condenser water inlet is 15 °C. The maximum condenser water inlet is 45°C.

Condenser water temperature (winter operation)

Once the system is on temperature, water temperature at the condenser inlet does not have to be less than 25 °C: lower values could cause incorrect working operation of the compressor and compressor failure may occur. The maximum water temperature at the condenser outlet does not have to exceed 50 °C: higher values will call the action of safety devices with unit stop.

Evaporator water temperature (winter operation)

The minimum evaporator water inlet temperature is 10°C. The maximum evaporator water inlet is 20 °C. In case of operation outside this range of temperatures please contact the company

CORRECTION TABLES Operation with glycol

Glicol percentage	Freezing point (°C)	CCF	IPCF	WFCF	PDCF
10	-3,2	0,985	1	1,02	1,08
20	-7,8	0,98	0,99	1,05	1,12
30	-14,1	0,97	0,98	1,09	1,22
40	-22,3	0,965	0,97	1,14	1,25
50	-33,8	0,955	0,965	1,2	1,33

CCF: Capacity correction factor
IPCF: Input power correction factor
WFCF: Water flow correction factor
PDCF: Pressure drops correction factor.

The water flow rate and pressure drop correction factors are to be applied directly to the values given for operation without glycol. The water flow rate correction factor is calculated in order to maintain the same temperature difference as that which would be obtained without glycol. The pressure drop correction factor takes into account the different flow rate obtained from the application of the flow rate correction factor.

CORRECTION TABLES different DT

Water temperature difference	3	5	8
CCCP	0,99	1	1,02
IPCF	0,99	1	1,01

CCCP = Cooling capacity correction factor. IPCF = Input power correction factor.

CORRECTION TABLES Different Fouling factors

Fouling factor	0,00005	0,0001	0,0002
CCCP	1	0,98	0,94
IPCF	1	0,98	0,95

CCCP = Cooling capacity correction factor. IPCF = Input power correction factor.

SOUND DATA

Mod.	Octave bands (Hz)								Lw		Lp
	63	125	250	500	1K	2K	4K	8K	dB	dB(A)	dB(A)
	dB	dB	dB	dB	dB	dB	dB	dB			
04	63,1	54,3	48,2	46,7	45,6	40,2	36,8	27,7	63,9	50	42
05	64,1	55,3	49,2	47,7	46,6	41,2	37,8	28,7	64,9	51	43
07	65,1	56,3	50,2	48,7	47,6	42,2	38,8	29,7	65,9	52	44
09	65,1	56,3	50,2	48,7	47,6	42,2	38,8	29,7	65,9	52	44
13	67,1	58,3	52,2	50,7	49,6	44,2	40,8	31,7	67,9	54	46
15	67,1	58,3	52,2	50,7	49,6	44,2	40,8	31,7	67,9	54	46
20	73,1	64,3	58,2	56,7	55,6	50,2	46,8	37,7	73,9	60	52
25	73,1	64,3	58,2	56,7	55,6	50,2	46,8	37,7	73,9	60	52
30	75,1	66,3	60,2	58,7	57,6	52,2	48,8	39,7	75,9	62	54
35	77,1	68,3	62,2	60,7	59,6	54,2	50,8	41,7	77,9	64	56
40	77,1	68,3	62,2	60,7	59,6	54,2	50,8	41,7	77,9	64	56

Lw: Sound power level according to ISO 3746.
 Lp: Sound pressure level measured at 10 mt from the unit in free field conditions direction factor Q=2 according to ISO 3746

SAFETY DEVICE SETTING

Device		Set-point	Differential	Differential
Control thermostat (summer)	°C	20	2	...
Control thermostat (winter)	°C	40	2	...
Anti-freeze thermostat	°C	4	6	MANUAL
Electric heater thermostat	°C	4	6	MANUAL
High pressure switch	Bar	28	7	MANUAL
Low pressure switch	Bar	0,7	1	MANUAL
Water safety valve (Optional)	Bar	6

ELECTRIC DATA

Power supply	V/-/Hz	400 / 3 / 50	Control board	V/-/Hz	24 / 1 / 50
Auxiliary circuit	V/-/Hz	230 / 1 / 50	Fans power supply	V/-/Hz	400 / 3 / 50

Electric data may change for updating. It is therefore necessary to refer always to the wiring diagram inside the units



WARNING: All the operation described in next chapters MUST BE DONE BY TRAINED PEOPLE ONLY. Before every operation of servicing on the unit, be sure that the electric supply is disconnected.

INSPECTION

When installing or servicing the unit, it is necessary to strictly follow the rules reported on this manual, to conform to all the specifications of the labels on the unit, and to take any possible precautions of the case. Not observing the rules reported on this manual can create dangerous situations. After receiving the unit, immediately check its integrity. The unit left the factory in perfect condition; any eventual damage must be questioned to the carrier and recorded on the Delivery Note before it is signed. HIDROS must be informed, within 8 days, of the extent of the damage. The Customer should prepare a written statement of any severe damage.

LIFTING AND HANDLING

When unloading the unit, it is highly recommended to avoid any sudden move in order to protect refrigerant circuit, copper tubes or any other unit component. Units can be lifted by using a forklift or, in alternative, using belts, being sure that the method of lifting does not damage the lateral panels and the cover. It is important to keep the unit horizontal at all time to avoid damages to the internal components.

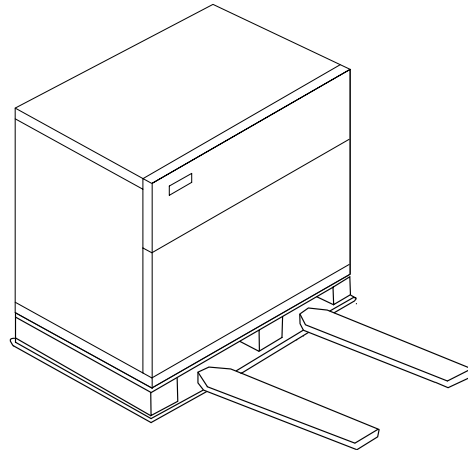

LOCATION AND MINIMUM TECHNICAL CLEARANCES

LSK units are designed for external installation: any cover over the unit and location near trees (even if they partially cover the unit) must be avoided in order to prevent air by-pass. It is advisable to create a proper basement, with a size similar to unit foot-print. Unit vibration level is very low: it is advisable however, to fit a rigid rubber band between basement and unit base-frame. If it is the case, it is possible to install anti-vibration mounts (spring or rubber), to keep vibrations at a very low level. Absolute care must be taken to ensure adequate air volume to the condenser. Re-circulation of discharge air must be avoided; failure to observe this point will result in poor performance or activation of safety controls. For these reasons it is necessary to observe the following clearances:

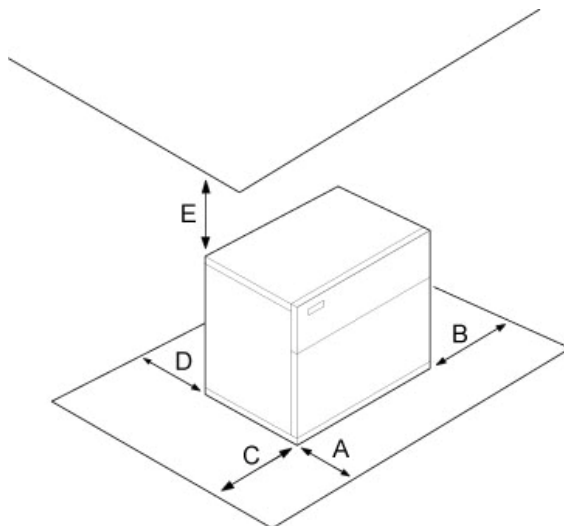

WSK STANDARD				
Mod	A	B	C	D
04	1000	500	500	500
05	1000	500	500	500
07	1000	500	500	500
09	1000	500	500	500
13	1000	500	500	500
15	1000	500	500	500
20	1000	500	500	500
25	1000	500	500	500

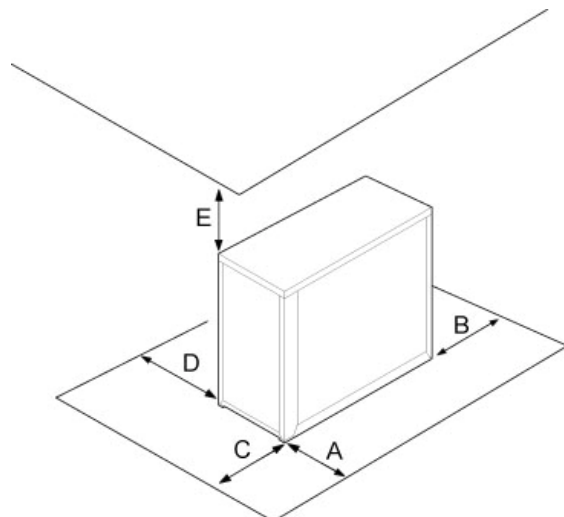

WSK/A1					
Mod	A	B	C	D	E
04A1	500	500	1000	500	500
05A1	500	500	1000	500	500
07A1	500	500	1000	500	500
09A1	500	500	1000	500	500
13A1	500	500	1000	500	500
15A1	500	500	1000	500	500
20A1	500	500	1000	500	500
25A1	500	500	1000	500	500
35A1	500	500	1000	500	500
40A1	500	500	1000	500	500



WARNING: The equipment should be installed so that maintenance and/or repair services be possible. The warranty does not cover costs due to lifting apparatus and platforms or other lifting systems required by the warranty interventions.



WARNING: All the maintenance operation must be done by TRAINED PEOPLE only. .



WARNING: Before any service operation on the unit, be sure that the electric supply is disconnected...



WARNING: Inside the unit some moving components are present. Be very careful when operating in their surroundings even if the electric supply is disconnected.



WARNING: The top shell and discharge line of compressor are usually at high temperature level. Be very careful when operating in their surroundings



WARNING: After servicing operation close the unit with cover panels, fixing them with locking screws.

HYDRAULIC CONNECTIONS

Unit water pipe-work must be installed in accordance with national and local regulation, pipes can be made either in steel , galvanized steel or PVC. Pipes have to be designed depending on the nominal water flow and the hydraulic pressure drops of the system. All pipes must be insulated with closed-cell material of adequate thickness. The chiller have to be connected to the piping by using flexible joints. Piping should include:

- Temperature and pressure gauges for the ordinary maintenance or servicing operations.
- Shut-off manual valves to separate the unit from the hydraulic circuit.
- Metallic filters to be mounted on the inlet pipe with a mesh not larger than 1 mm.
- Vent valves, expansion tank with water filling, discharge valve.



WARNING: Unit water inlet must be in correspondence with the connection labelled: "USER WATER IN", otherwise the heat exchangers may freeze.

WARNING: It is compulsory to install on the USER WATER IN connection a metallic filter with a mesh not larger than 1 mm. The presence of the filter is to be considered mandatory, the warranty will no longer be valid if it is removed. The filter must be kept clean, so make sure it is clean after the unit has been installed, and then check it periodically



WARNING: All units are factory supplied with the flow switch (it is factory installed in the "A" versions, supplied loose in the standard versions). The flow switch **MUST BE INSTALLED** on the water outlet connection (labelled USER WATER OUT); If the flow switch is altered, removed, or the water filter should not be present on the unit, the warranty will be invalidated. Please refer to the wiring diagram for flow switch electric connections..

Basic version hydraulic components

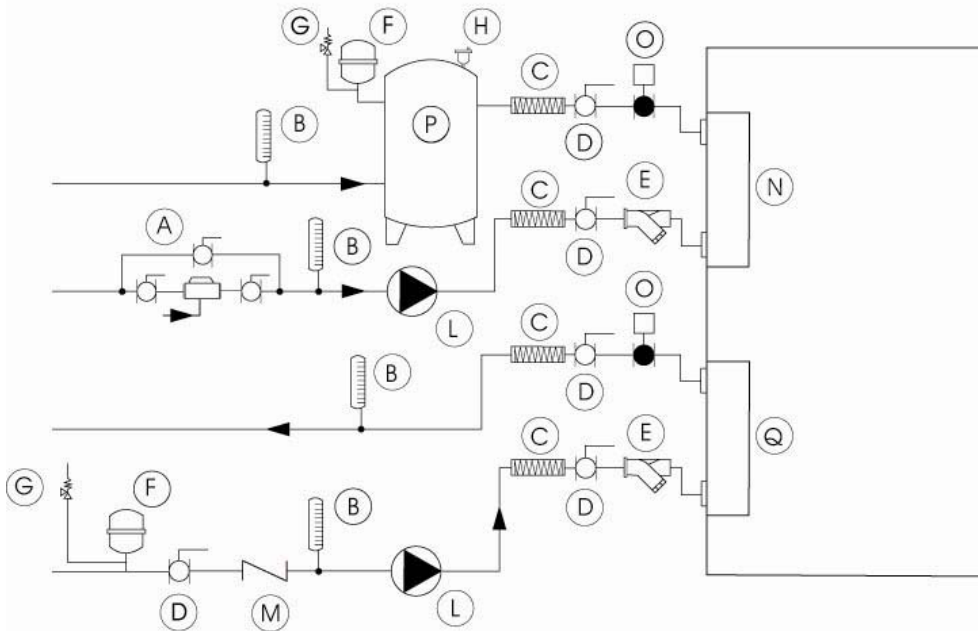

“A” version hydraulic components

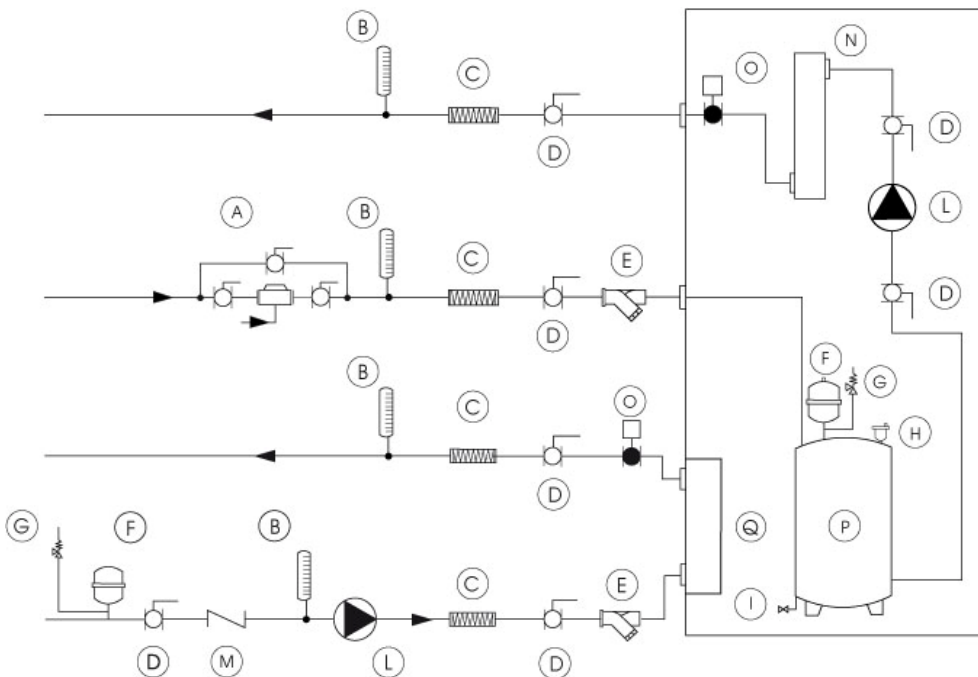

A	System filling group	I	Water tank Drainage valve
B	Thermometer	L	Water pump
C	Flexible connection	M	One way valve
D	Ball shut-off valve	N	Evaporator
E	Water strainer	O	Flow switch
F	Expansion vessel	P	Water tank
G	Safety valve	Q	Condenser
H	Vent valve		

ELECTRICAL CONNECTIONS

It must be verified that electric supply is corresponding to the unit electric nominal data (tension, phases, frequency) reported on the label in the front panel of the unit. Power connections must be made in accordance to the wiring diagram enclosed with the unit and in accordance to the norms in force. Power cable and line protection must be sized according to the specification reported on the form of the wiring diagram enclosed with the unit.



WARNING: The line voltage fluctuations can not be more than $\pm 5\%$ of the nominal value, while the voltage unbalance between one phase and another can not exceed 2%. If those tolerances should not be respected, please contact our Company.



WARNING: Electric supply must be in the limits shown: in the opposite case warranty will terminate immediately. Before every operation on the electric section, be sure that the electric supply is disconnected.

WARNING: The Flow switch must be connected following the indication reported in the wiring diagram. Never bridge the flow switch connections in the terminal board. Guarantee will be invalidated if flow switch connections are altered or not properly made..



WARNING: The remote control panel is connected to the water chiller by 2 wires of 2,5 mm² section. Power supply cables must be separated by remote control wires. Maximum distance 50 metres



WARNING: The remote control panel can not be installed in area in with strong vibrations, corrosive gases, excess of dirtiness or high humidity level. Leave free the area near the cooling openings

START UP

Before start-up

- Check that all power cables are properly connected and all terminals are hardly fixed.
- The voltage at the phase R S T is the one shown in the unit labels.
- Check that there is not any refrigerant leakage.
- Check that crankcase heaters are powered correctly.
- Check that all water connections are properly installed and all indications on unit labels are observed.
- The system must be bleed off in order to eliminate any air.
- Before start up check that all the cover panel are re-located in the proper position and locked with fastening screws.



WARNING: Crankcase heaters must be powered at least **12 hours before start up** by closing the main switch (heaters are automatically supplied when main switch is closed). The crankcase heaters are working properly if after some minutes the compressor crankcase temperature is about $10\pm 15^{\circ}\text{C}$ higher than ambient temperature

Start up and switch off

Push  for 5 seconds to run the unit in heating mode. Push the same key for 5 seconds to switch off.

Push  for 5 seconds to run the unit in cooling mode. Push the same key for 5 seconds to switch off



WARNING: Never switch off the unit (for temporary stop), by opening the main switch: this component should be used only to disconnect the unit from power supply when the current is not passing through, i.e. when the unit is in OFF mode. Moreover, with no supply to crankcase heater, at the unit start up, compressor could be seriously damaged..

WARNING: Do not modify internal wiring of the unit otherwise warranty will terminate immediately.



WARNING: for heat pump versions, the summer/winter operation must be selected at the beginning of the related season. Frequent change over of the seasonal operation mode must be avoided in order to prevent severe damage to compressors.

MICROPROCESSOR USER INTERFACE



Display

The display area is divided in three parts:

Left Upper Side : It shows the evaporator “water IN / OUT” temperature.

Left Lower Side : It shows the temperature or the pressure of the condenser and the clock time.

Right Side: Icon area.

Display icons

Icon	Meaning	Icon	Meaning
°C	Celsius degrees	H	High pressure Alarm
°F	Fahrenheit degrees	L	Low pressure Alarm
bar	Bar	⚡	Anti-freeze electric heater activated
PSI	Psi	IR	Infrared Transmission activated
1	Compressor 1	Flow!	Water Flow Alarm
2	Compressor 2	⌚	The display is showing a time value
Zz	Unit in Stand-by	🔧	Compressor Maintenance Request
⚠	General Alarm	Menu	Function Menu activated

Key function



M to enter the function Menu or to set the clock.



SET allows to show and modify the set point. In programming mode it selects a parameter and confirm its value.



Push it for 5 s to run the unit in Chiller mode. Push and release to change the read-out between “IN/OUT water” / supplied air. In programming mode it scrolls the parameter list or increases the value of the parameter itself.



Push it for 5 s to run the unit in Heat Pump mode. Push and release to change the read-out between “outside air” / defrost temp. In programming mode it scrolls the parameter list or decreases the value of the parameter itself.

Key combination

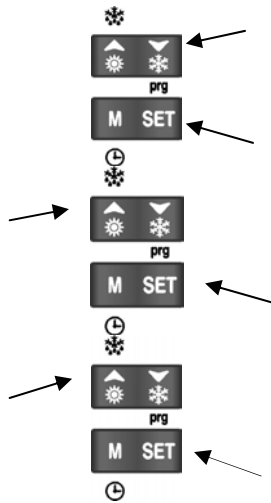

Press **SET** and **DOWN** key to Enter the programming.

Press **SET** and **UP** key to Exit the programming

Push them together for more than 5 sec to start a manual defrost

Keyboard leds

Symbol	Led	Function	Symbol	Led	Function
	On	Heat pump		Blinking	Time delay before defrosting
	On	Chiller		On	Defrost On
	Blinking	Programming phase (It blinks with led)		Off	Defrost Off
					Clock Set-up

Normal condition read-out



If no alarm conditions are present, the display shows:

Left upper side: Evaporator water Inlet/Outlet temperature.

Left lower side: Condensing Temperature / Pressure; The clock.

REMOTE KEYBOARD



Key function

	M allows to enter the menu or to set the clock time..
	SET allows to show and modify the set point. During the programming it selects a parameter and confirm its value
	It selects the water IN / OUT or the ambient air read-outs. During the programming it scrolls the parameter code or increases its value.
	It selects the external /defrost air temperature read-out. During the programming it scrolls the parameter code or decreases its value.
	If pushed for 5s it allows to start the unit in chiller or heat pump function..
	If pushed for 5s it allows to start the unit in chiller or heat pump function.

Alarm read-out



Starting from the normal condition (no alarms), when the instrument detects an alarm event, the left lower side shows the alarm code alternated with the probe value. The corresponding icon lighted. The following four icons are dedicated to a better alarm understanding:

	Generic Alarm		High pressure alarm
	Low pressure alarm		Water flow Alarm

Silencing the buzzer

Automatically: just after the alarm condition is recovered.

Manually: push and release one of the four keys; the buzzer is stopped even if the alarm is still active.

First start up

After giving power supply to the instrument, the left lower display can show “rtC” alternated with the probe value: **it is necessary to set the clock time**. If the probes are not connected, or they are faulty, the display shows even the corresponding alarm code. In any case it is possible to proceed with the parameter or clock setting.

How to set the clock rtc

Push the **M** key for some seconds and wait until the “Hour” label appears. Release the M key. Now push **SET**: the hour value starts blinking. Use the **UP** and **DOWN** key to change the value. Confirm by pushing **SET**; After some seconds the controller will show the next parameter (Min).

Repeat the operation to set the other parameters:

Min: Minutes (0÷60)

UdAy Weekday (**Sun** Sunday, **Mon** Monday, **tuE** Tuesday, **UEd** Wednesday, **tHu** Thursday, **Fri** Friday, **SAt** Saturday).

dAy Day of the month(0÷31)

MntH Month (1÷12)

yEAR Year (00÷99)

Display read-out when remote on/off

The digital input configured as remote OFF: if activated it turns off the controller (also for condensing units), upper display shows “OFF” the decimal point led is blinking. This remote on/off command overrides the instrument keyboard commands. The keyboard commands are active only when the digital input is not active. When the remote off is not activated the controller automatically restarts.

Stand- by function

Each time the Chiller or Heat Pump cycles are stopped, the unit goes in stand-by and the  icon turns on. The controller stand-by allows to:

Show the probe values using key arrows.

Show and manage the alarm events.

“M key” the function menu

Entering the function Menu allows to:

Show and reset the active alarms.

Show and reset the time running hour counters of the loads.

Enable the infra-red communication device.

Show the time delay to achieve and start the defrost (only for Heat Pump).

Upload the parameters from the controller to the Hot Key (see 10.2).

Show the alarm log.

Reset the alarm log.

During the Menu operations the “menu” icon is on.

Access to function menu

Push and release the **M** key. The ” menu” icon is on. Push and release the **M** key or wait the time out. The “menu” icon disappears.

How to show the alarm events

Enter the function Menu:

Use **UP** or **DOWN** keys to find the “ALrM” label.

Push and release the **SET** key.

Use **UP** or **DOWN** keys to scroll the alarm list.

To exit the function Menu push and release the **M** key or wait the time-out. The “menu” icon disappears

How to reset an alarm event

Enter the function Menu.

Use **UP** or **DOWN** keys to find the “ALrM” label.

Push and release the **SET** key, the lower display shows the alarm code.

Upper display: **rSt** label if the alarm can be reset, **NO** label if it is not possible.

Use **UP** or **DOWN** keys to scroll the alarm list.

Push **SET** key, when **rSt** is lighted, to reset the alarm, after a while the read-out move to next alarm.

To exit the function menu push and release the **M** key or wait the time-out. The “menu” icon disappears.

Time running hour counter of the loads

Enter the function Menu.

Use **UP** or **DOWN** keys to find on the lower display:

C1Hr (Compressor n°1 hour counter),

C2Hr (Compressor n°2 hour counter),

PFHr (Water pump or supply fan hour counter).

The upper display shows the time running hour value. The clock icon  is lighted.

Reset the hour counters

Enter the function Menu.

Use **o** or **n** keys to find on the lower display the C1Hr, C2Hr or PFHr.

Push **SET** key for 3seconds: the upper display turns to 0 indicating the reset.

To exit the function menu push and release the **M** key or wait the time-out. The “menu” icon disappears.

Show the time delay to start the defrost

Enter the function Menu.

Use **o** or **n** keys to find, on the upper display, the **dEF** (defrost) label, the lower display shows the time delay to reach and start the defrost (minutes and seconds), the icon  is blinking.

To exit the function menu push and release the **M** key or wait the time-out. The “menu” icon disappears.

How to see the alarm log

Enter the function Menu.

Use **o** or **n** keys to find **ALOG** label.

Push **SET** key: the lower display shows the alarm code, the upper display shows “n°” followed by the progressive number.

With **o** or **n** scroll the alarm list.

To exit from **ALOG** function push **M** key or wait the time-out delay is expired.

The memory contains **50** alarm events structured in a FIFO list. Each new alarm will take the place of the oldest alarm contained in the FIFO list. (the read-out is ordered from the oldest to the newest)

How to reset the alarm log

Enter the function Menu.

Select the **ALOG** label showed on the lower display.

Push **SET** key.

Select with **o** or **n** keys the **ArSt** (Alarm reset) label on the lower display, the upper display is **PAS**.

Push **SET** key and then enter the password **PAS**, upper display shows **0** blinking.

Write the right password number.

The **ArSt** label starts blinking for **5s**, to confirm the alarm logging data is reset.

After finishing the display restarts from normal condition.

How to see the set point value

Push and release the **SET** key.

Lower display shows: **SetC** set of chiller mode; **SetH** set of heat pump mode.

The upper display shows the corresponding set value. (SetH is available only if configured for Heat Pump).

How to change the set point value

Push **SET** key for more than **3** seconds.

The setpoint value is now blinking.

Use **UP** or **DOWN** keys to increase or decrease the new value.

When finishing, push and release **SET** key again or wait for the time-out to exit the programming.

Maintenance function

CO14 for 1st compressor, **CO15** for 2nd compressor and **CO16** for water pump or supplied air fan (air/air) are the maximum time running hours to signal a maintenance request, the icon  is blinking. The icon only indicates the need of a check: **nothing else happens**. It stops blinking just after resetting the hour counter under the function Menu.

Black out

After a black-out: The controller restarts from the pervious status; The defrost cycle is stopped; All the working time delay will be reloaded.

CONTROLS DURING UNIT OPERATION

- Check the fans rotation. If the rotation is incorrect, disconnect the main switch and change over any two phases of the incoming main supply to reverse motor rotation (only for units with three-phase fan motors).
- Check that water temperature at evaporator inlet is near to the set point of the control thermostat.
- For "A" version units (units with pumps and storage tank) if the motor driven pump should be noisy, slowly close discharge shut-off valve until normal working conditions are restored. This trouble may occur when system pressure drop is quite different from pump available pressure.

Refrigerant charge checking

- After few hours the unit is working, check that sight glass shows a green colour core: if the core is yellow moisture would be present in the circuit. In this case it is necessary circuit dehydration to be carried out by qualified people only. Check that at the sight glass there is no continuous vapour bubbles presence. In this case additional refrigerant charge could be required. It is however allowed the presence of few vapour bubbles.
- Few minutes after the start up, working on summer operating mode (cooling), check that condensing temperature, is approximately 15 °C higher than condenser inlet air temperature. Check moreover that evaporation temperature is about 5 °C lower than the evaporator outlet temperature.
- Check that refrigerant superheat on the evaporator is about 5-7 °C
- Check if refrigerant sub-cooling on the condenser is about 5-7 °C.

MAINTENANCE AND PERIODIC CHECK



WARNING: All this operation described in this chapter MUST BE DONE BY TRAINED PEOPLE ONLY. Before every operation of servicing on the unit, be sure that the electric supply is disconnected. The top shell and discharge line of compressor are usually at high temperature level. Be very careful when operating in their surroundings. Aluminium coil fins are very sharp and can cause serious wounds. Be very careful when operating in their surroundings. After servicing operation close the unit with cover panels, fixing them with locking screws

It is a good rule to carry on periodic checks in order to verify the correct working of the unit.

- Check that safety and control devices work correctly as previously described (monthly).
- Check all the terminals on the electric board and on the compressor are properly fixed.
- Check and clean the sliding terminals of the contactors.
- Check refrigerant charge by sight glass; check leakages from compressor (monthly).
- Check water leakages in the hydraulic system (monthly).
- If the unit is to be expected to be stopped for a long period, unit hydraulic circuit should be emptied from all the tubes and heat exchanger. This operation is compulsory if, during seasonal stop, ambient temperature is expected to go down below the freezing point of employed mixture (typical seasonal operation).
- Check flow switch proper working, clean metallic filters on water piping (monthly).
- Check compressor crankcase heater proper supply and functioning (monthly).
- Check the colour of the sight glass core (green=no moisture, yellow=moisture present): if it has a yellow colour, change the refrigerant filter (every 4 months).

REFRIGERANT CIRCUIT REPAIR

In the case that refrigerant circuit should be discharged, all the refrigerant must be recovered with proper machines. The system must be charged with nitrogen, using a gas bottle with a pressure reducing valve, until 15 bar pressure is reached. Any eventual leakage must be searched with a bubble leak finder. In case bubbles appear discharge the circuit before welding with proper alloys.



WARNING: Never use oxygen instead of nitrogen: explosions may occur.

ENVIRONMENT PROTECTION

According to European norms dealing with the use of depleting stratospheric ozone substances, it is forbidden to release refrigerants fluids in the atmosphere. They must be redelivered to the seller or to proper gathering points at the end of their operating life. Refrigerant R407C is mentioned among controlled substances and for this reason it must be subjected to the mentioned norms. A particular care is recommended during service operations in order to reduce as much as possible any refrigerant loss.

UNIT OUT OF SERVICE

Once the unit is arrived at the end of its life and needs to be removed or replaced, the following operations are recommended:

- the unit refrigerant has to be recovered by trained people and sent to proper collecting centre;
- compressor lubricating oil has to be recovered and sent to proper collecting centre;
- the frame and various components, if not usable any longer, have to be dismantled and divided according to their nature; particularly copper and aluminium, which are present in conspicuous quantity in the unit. These operations allow easy material recover and recycling process, reducing environmental impact.

FAULT FINDING

Cod	Meaning	Cause / Origin	Reset
P1	Pb1 probe alarm	Missing, faulty probe or resistance exceeding value	Automatic if the probe value recovers
P2	Pb2 probe alarm	Missing, faulty probe or resistance exceeding value	Automatic if the probe value recovers
P3	Pb3 probe alarm	Missing, faulty probe or resistance /current exceeding value	Automatic if the probe value recovers
P4	Pb4 probe alarm	Missing, faulty probe or resistance exceeding value	Automatic if the probe value recovers
A01	High pressure switch alarm	Digital input for high pressure activated	Manual after the alarm event expires, proceed with manual reset.
A02	Low pressure switch alarm	Digital input for low pressure activated	Manual after the alarm event expires, proceed with manual reset.

Cod	Meaning	Cause / Origin	Reset
A07	Anti freeze alarm	Digital input active anti freeze probe	Manual proceed with manual reset.
A08	Water flow alarm	Digital input active for AL06 duration.	Automatic It turns to manual after 3 events in 1 hour.
A09	Compressor 1 thermal protection alarm	Digital input active	Manual the event expires, then proceed with manual reset.
A10	Compressor 2 thermal protection alarm	Digital input active	Manual the event expires, then proceed with manual reset.
A11	---	---	---
A12	Defrost error alarm	Max defrost time	Automatic with next proper defrost cycle. Proceed with manual reset.
A13	Compressor 1 maintenance warning	Running hour > CO14	Manual Proceed with the hour reset procedure.
A14	Compressor 2 maintenance warning	Running hour > CO15	Manual Proceed with the hour reset procedure
A15	Water pump maintenance Warning	Running hour warning	Manual Proceed with the hour reset procedure
rtC	Clock alarm	Need to set the clock time	Manual Set the clock and then proceed with manual reset.
rtF	Clock alarm	Faulty clock control	Manual Proceed with manual reset, if nothing happens change the clock.
EE	EEPROM error alarm	Possible data losing	Manual Proceed with manual reset., if nothing happens the controller is locked, no regulation available.
ACF1	Configuration alarm	Heat pump configured without reversing valve	Automatic After parameter proper debug.
ACF2	Configuration alarm	without condensing probe control configuration	Automatic After parameter proper debug.
ACF3	Configuration alarm	Two digital inputs having the same function	Automatic After parameter proper debug.
FErr	Functioning alarm	Two digital inputs activated at the same time	Manual after the alarm event expires, proceed with manual reset.
AFr	Frequency alarm	The frequency of power supply is out of range	Automatic After the frequency becomes normal

VISTA FRONTALE
FRONT VIEW

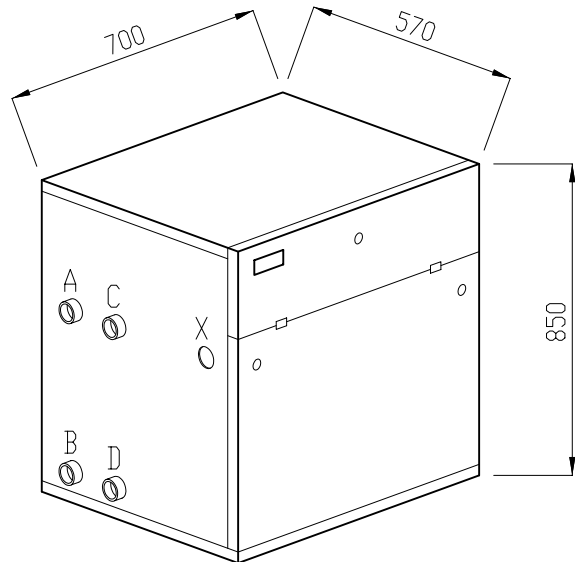
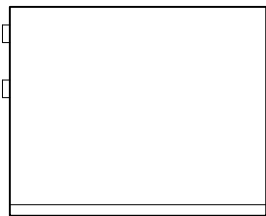
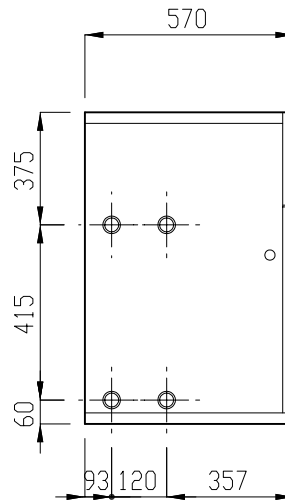
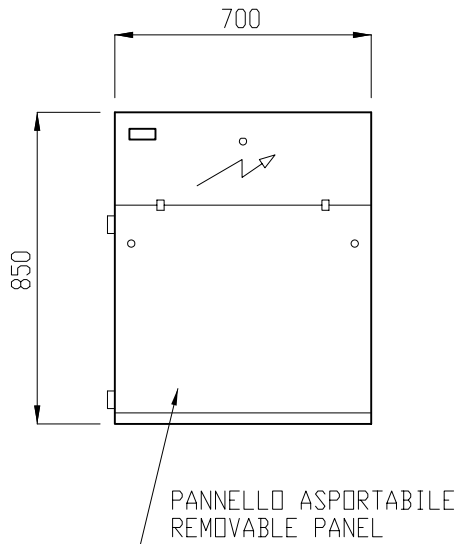

A	INGRESSO ACQUA UTENTE	USER WATER INLET
B	USCITA ACQUA UTENTE	USER WATER OUTLET
C	USCITA ACQUA CIRCUITO ESTERNO	EXTERNAL CIRCUIT WATER OUTLET
D	INGRESSO ACQUA CIRCUITO ESTERNO	EXTERNAL CIRCUIT WATER INLET
X	ALIMENTAZIONE ELETTRICA	POWER SUPPLY

2-FRONT

Rev.	Data-Date	Dis.-Draftsman	Visto-Checked by	Descrizione revisione-Revision description		
-	-	-	-			
Denominazione-Denomination SCHEMA DIMENSIONALE REFRIGERATORE WSK / WRK 04-05-09-13-15				Codice-Code	Disegno-Drawing DXDI-0045B	Rev. A
	Scala-Scale 1:20	Data-Date 17-06-04	Dis.-Draftsman D. GRINZATO	Visto-Checked by	Foglio-Sheet N. 1 di 1 of 1	HIDROS DEUMIDIFICAZIONE UMIDIFICAZIONE
Sost. il dis.-Replace draw.			Sost. dal dis.-Replaced by draw.		Ordine-Order	
Materiale-Material			Trattamento-Treatment		Peso-Weight (kg)	Proprietà riservata-Riproduzione vietata a termini di legge-Copyright

VISTA FRONTALE
FRONT VIEW

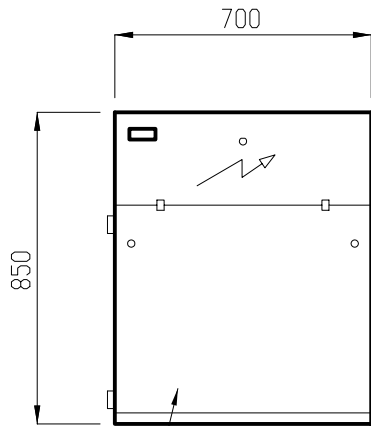

PANNELLO ASPORTABILE
REMOVABLE PANEL

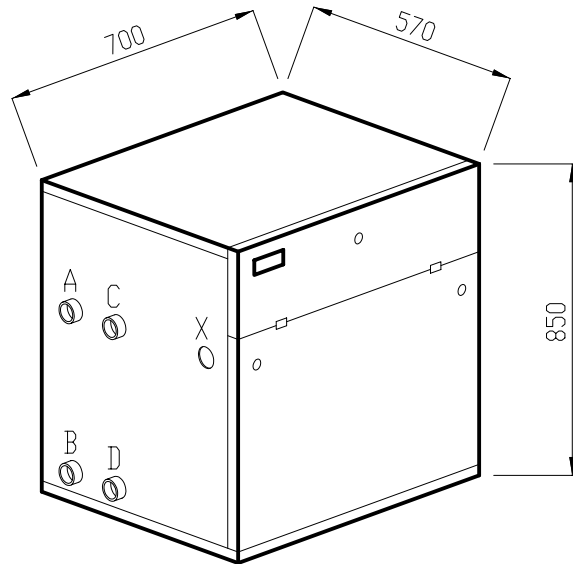
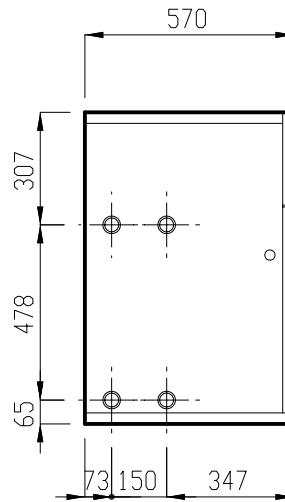

A	INGRESSO ACQUA UTENTE	USER WATER INLET
B	USCITA ACQUA UTENTE	USER WATER OUTLET
C	USCITA ACQUA CIRCUITO ESTERNO	EXTERNAL CIRCUIT WATER OUTLET
D	INGRESSO ACQUA CIRCUITO ESTERNO	EXTERNAL CIRCUIT WATER INLET
X	ALIMENTAZIONE ELETTRICA	POWER SUPPLY

2 - FRONT

Rev.	Data-Date	Dis.-Draftsman	Visto-Checked by	Descrizione revisione-Revision description		
-	-	-	-			
Denominazione-Denomination SCHEMA DIMENSIONALE REFRIGERATORE WSK / WRK 20 - 25 - 30 - 35 - 40				Codice-Code	Disegno-Drawing DXDI-0045	Rev. A
	Scala-Scale 1:20	Data-Date 17-06-04	Dis.-Draftsman D. GRINZATO	Visto-Checked by	Foglio-Sheet N. 1 of 1	HIDROS DEUMIDIFICAZIONE UMIDIFICAZIONE
Sost. il dis.-Replace draw.			Sost. dal dis.-Replaced by draw.		Ordine-Order	
Materiale-Material			Trattamento-Treatment		Peso-Weight (kg)	Proprietà riservata-Riproduzione vietata a termini di legge-Copyright

FRONTE UNITA'
FRONT VIEW

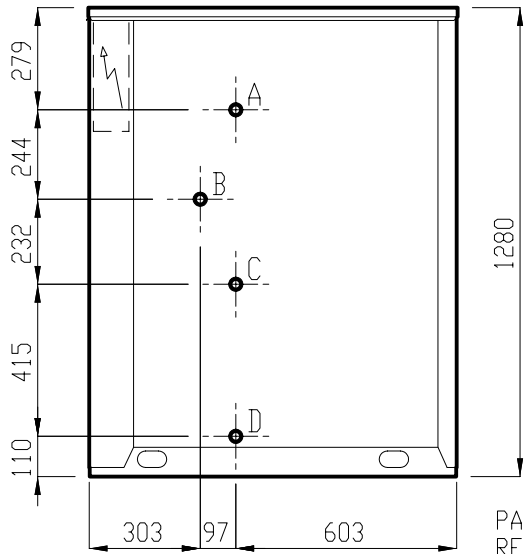

PANNELLO ASPORTABILE
REMOVABLE PANEL

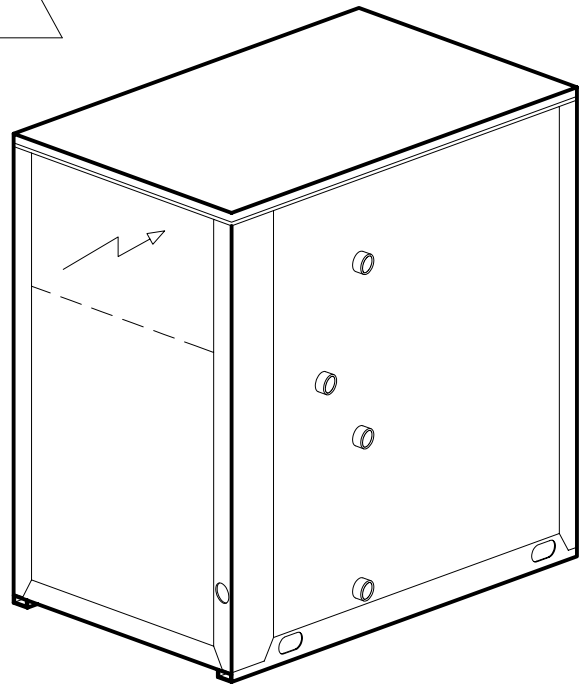
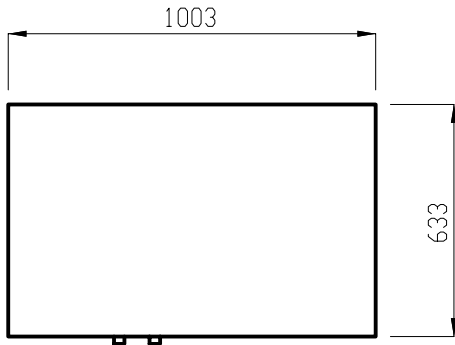
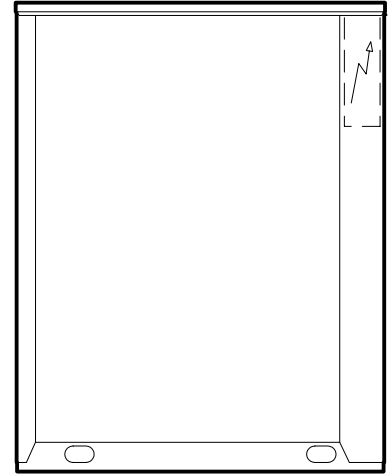
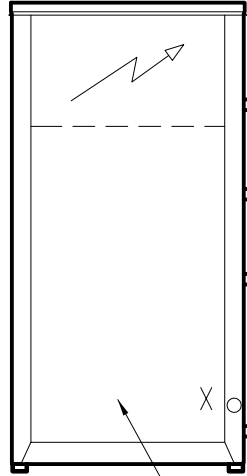

A	INGRESSO ACQUA UTENTE	USER WATER INLET
B	USCITA ACQUA UTENTE	USER WATER OUTLET
C	USCITA ACQUA CIRCUITO ESTERNO	EXTERNAL CIRCUIT WATER OUTLET
D	INGRESSO ACQUA CIRCUITO ESTERNO	EXTERNAL CIRCUIT WATER INLET
X	ALIMENTAZIONE ELETTRICA	POWER SUPPLY

8 - FRONT

Rev.	Data-Date	Dis.-Draftsman	Visto-Checked by	Descrizione revisione-Revision description		
-	-	-	-			
Denominazione-Denomination				Codice-Code	Disegno-Drawing	Rev.
SCHEMA DIMENSIONALE REFRIGERATORE					DXDI-0046	A
WSK / WRK A1 05 - 07 - 09 -13 - 15						
	Scala-Scale	Data-Date	Dis.-Draftsman	Visto-Checked by	Foglio-Sheet N. 1 of 1	HIDROS DEUMIDIFICAZIONE UMIDIFICAZIONE
	1:20	17-06-04	D. GRINZATO		Ordine-Order	
Sost. il dis.-Replace draw.			Sost. dal dis.-Replaced by draw.		Peso-Weight (kg)	Proprietà riservata-Riproduzione vietata a termini di legge-Copyright
Materiale-Material			Trattamento-Treatment			

FRONTE UNITA'
FRONT VIEW

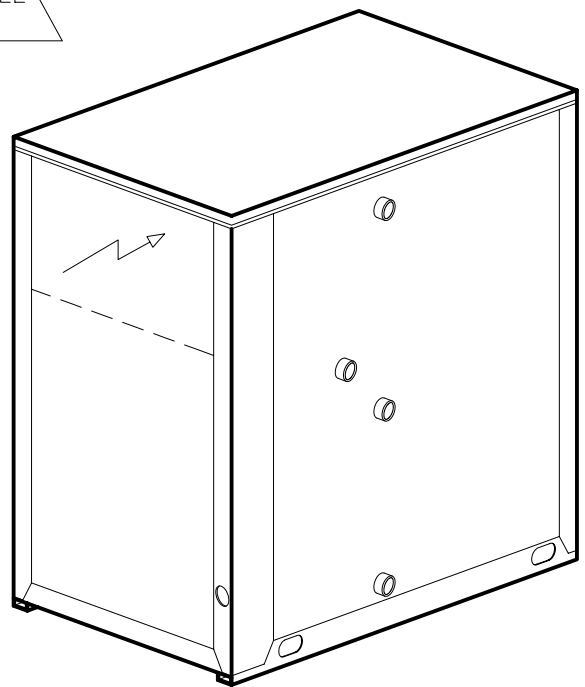
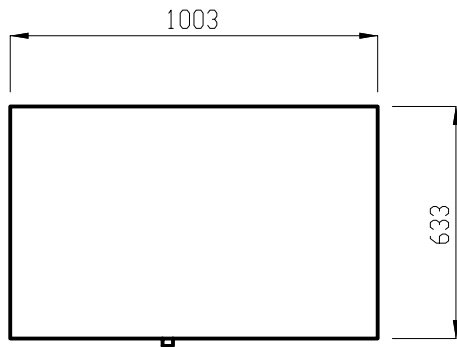
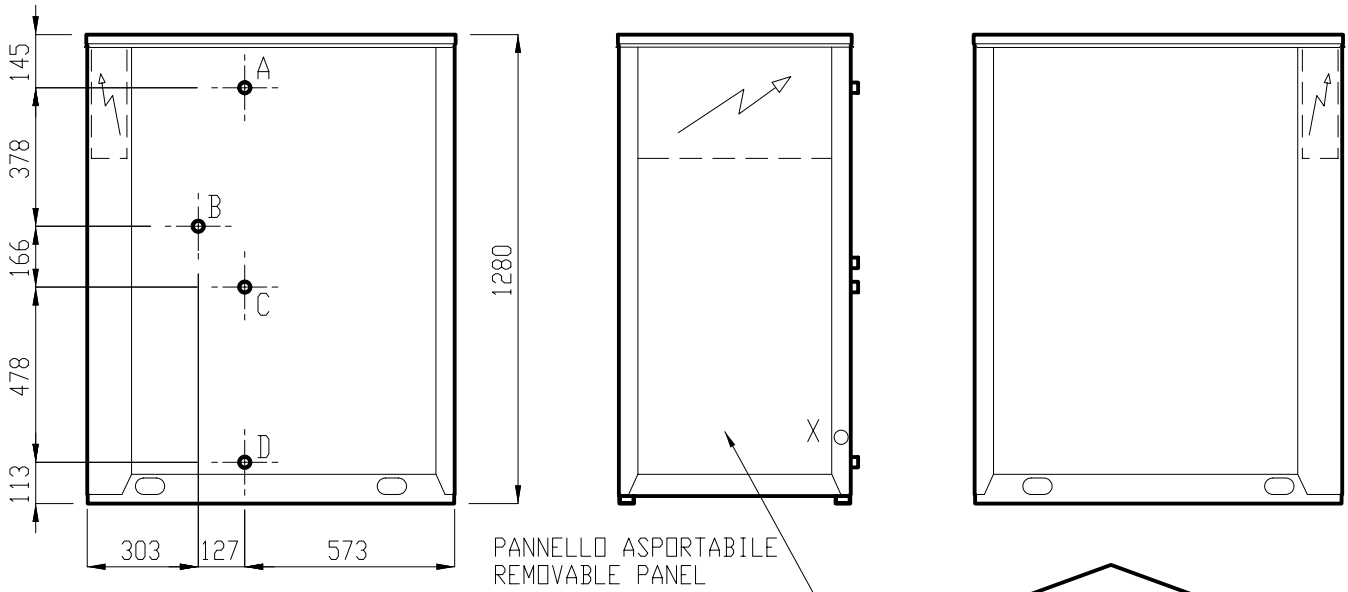

A	INGRESSO ACQUA UTENTE	USER WATER INLET
B	USCITA ACQUA UTENTE	USER WATER OUTLET
C	USCITA ACQUA CIRCUITO ESTERNO	EXTERNAL CIRCUIT WATER OUTLET
D	INGRESSO ACQUA CIRCUITO ESTERNO	EXTERNAL CIRCUIT WATER INLET
X	ALIMENTAZIONE ELETTRICA	POWER SUPPLY

8 - FRONT

Rev.	Data-Date	Dis.-Draftsman	Visto-Checked by	Descrizione revisione-Revision description
-	-	-	-	-
Denominazione-Denomination SCHEMA DIMENSIONALE REFRIGERATORE WSK / WRK A1 20 - 25 - 30 - 35 - 40				Codice-Code DXDI-0047
Disegno-Drawing A		Rev. A		
	Scala-Scale 1:20	Data-Date 17-06-04	Dis.-Draftsman D. GRINZATO	Visto-Checked by
Sost. il dis.-Replace draw.		Sost. dal dis.-Replaced by draw.		Foglio-Sheet N. 1 di 1 of 1
Materiale-Material		Trattamento-Treatment		Ordine-Order
				Peso-Weight (kg)
HIDROS DEUMIDIFICAZIONE UMIDIFICAZIONE				
Proprietà riservata-Riproduzione vietata a termini di legge-Copyright				

HIDROS

HIDROS srl
Via dell'Industria 5
35020 Brugine (Pd)
Tel. +390-49-9731022
Fax. +390-49-5806928
Info@hidros.it
www.hidros.it

I dati tecnici riportati nella presente documentazione non sono impegnativi.
HIDROS SRL. si riserva la facoltà di apportare in qualsiasi momento tutte le modifiche necessarie per il miglioramento del prodotto.